

SIoux STEEL COMPANY



L
U
S
T
R
U
M

GRAIN HANDLING EQUIPMENT

*Grain Legs, Cat Walks,
Towers, Conveyors,
& Accessories*

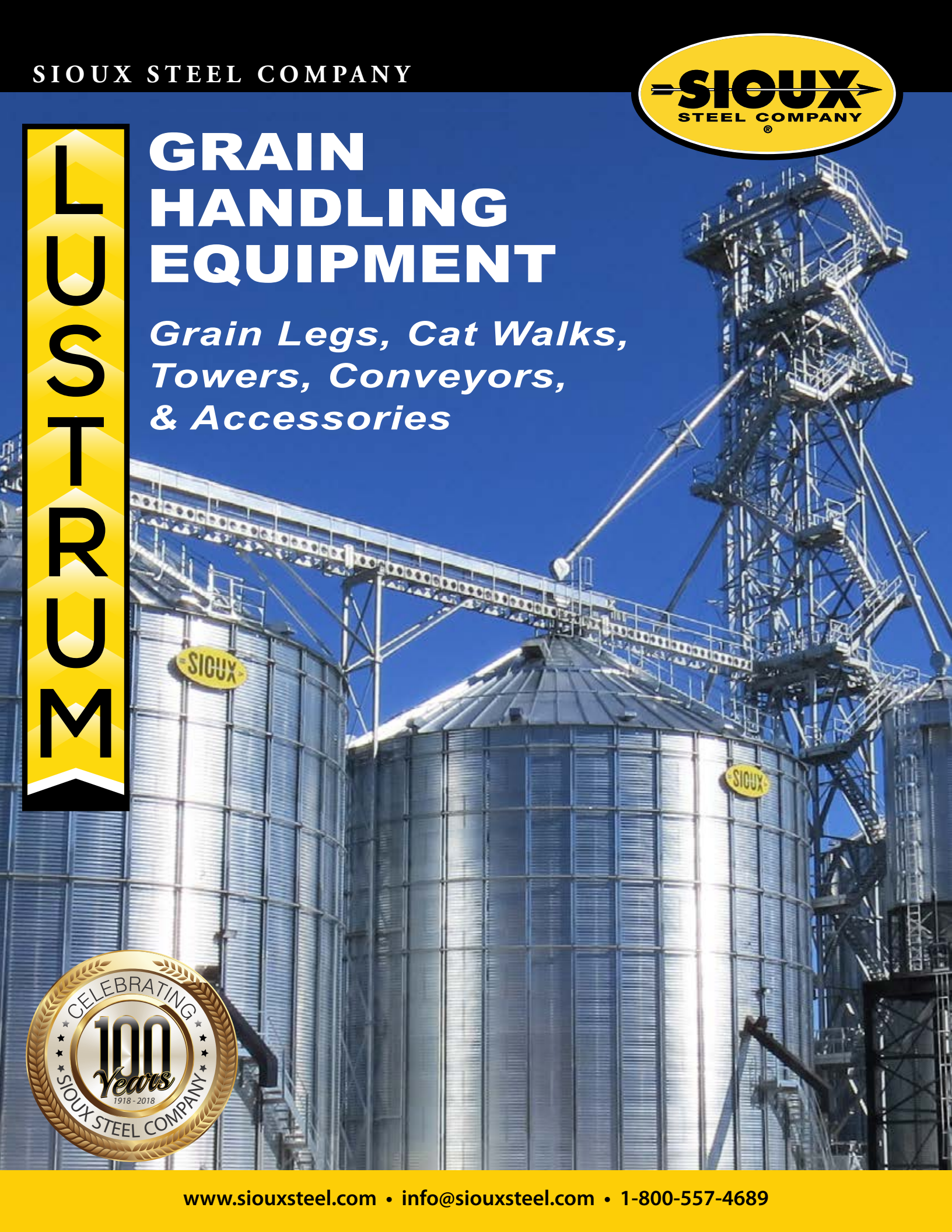



GRAIN HANDLING EQUIPMENT

SIoux STEEL COMPANY

ENGINEERING PROGRESSIVE SOLUTIONS SINCE 1918

What makes Sioux Steel Company unique?

- Products with the longest warranties in the industry.
- Committed to helping find the right solution for each customer.
- Pioneers of building stronger products with the highest ratings.
- Products that have proven themselves since 1918.
- 4th generation, family-owned company.



**Innovative Solutions
Manufactured By A
Family-Owned
Company With A
Century's Worth
Of Experience**

SIOUX STEEL PRODUCTS ARE
MADE IN THE USA

Complete Storage Systems

Sioux Steel Company is committed to designing and manufacturing the highest quality, complete grain storage systems for your needs.









Our selection of grain handling equipment provides you with the reliability and dependability to keep your operation running smoothly.

Solutions for Today and Tomorrow

For more information about Sioux Steel
COMMERCIAL & FARM BINS
visit us online at
www.siouxsteel.com

Stay Connected With Us

Curious about our latest news and events? Want to learn more about our new and existing products? A complete Sioux Steel experience awaits when you join our global community.

-  facebook.com/siouxsteel
-  twitter.com/siouxsteel
-  instagram.com/siouxsteel
-  plus.google.com/+SiouxSteel
-  youtube.com/siouxsteel
-  pinterest.com/siouxsteel
-  linkedin.com/company/sioux-steel-company
-  info@siouxsteel.com

GRAIN LEGS

DIMENSIONS & FEATURES

8" TO 42" HEAD PULLEY & DRUM 500 TO 20,000 BPH

GRAIN LEG DIMENSIONS

	A	B	C	D	E	F	G	I	Inlet H
8"	68"	48"	42"	30"	14"	30"	24"		39"
24"	96"	73"	50.5"	42"	15"	10"	27"	23.5"	48"
30"	110"	87"	56"	53"	18"	12"	32"	27.5"	53"
36"	126"	96"	62.25"	58"	18"	12"	34"	27.5"	58.25"
42"	137"	108"	69"	65"	23"	13"	40.5"	33"	65.19"

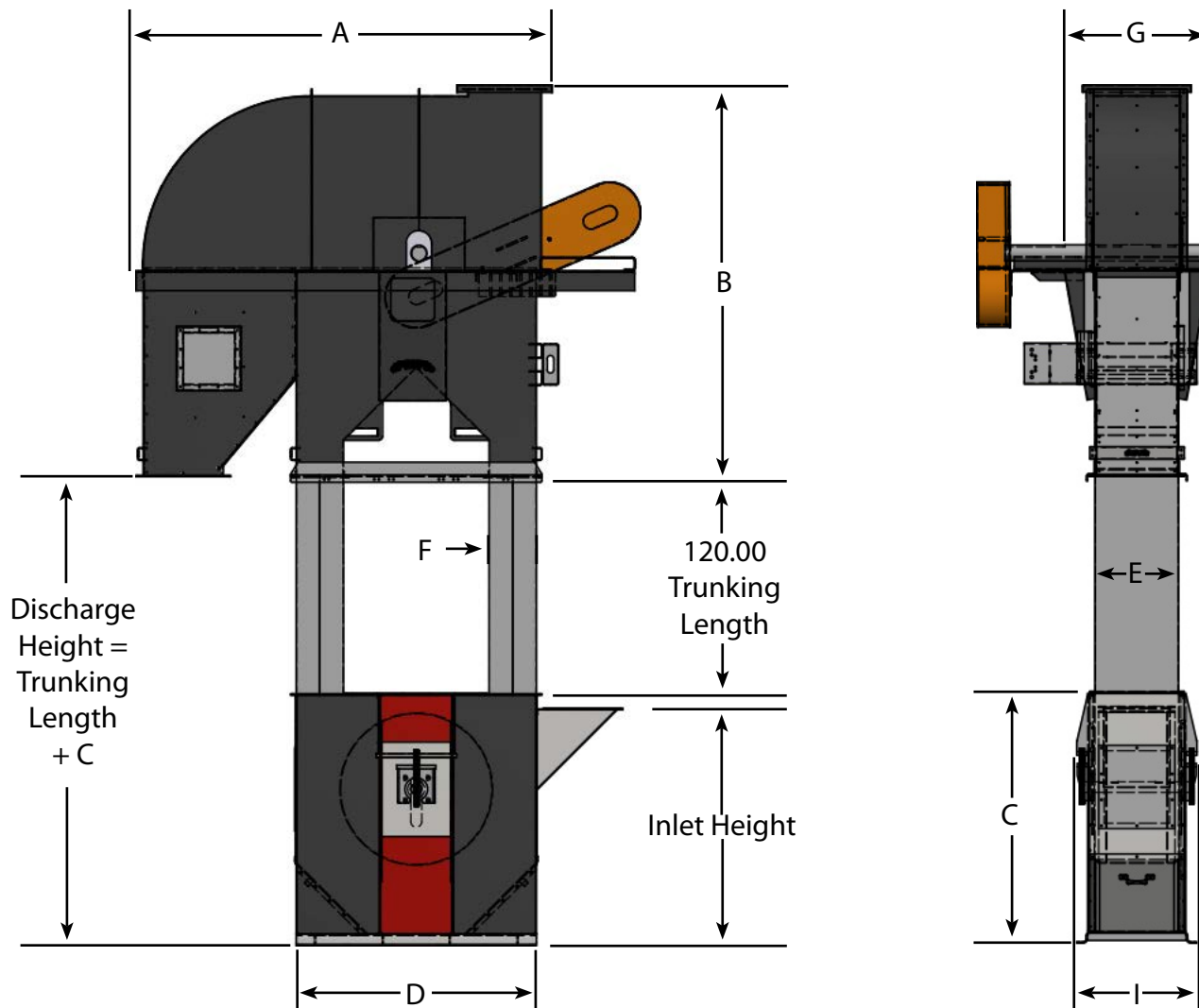



CUSTOM BUILT TO YOUR SPECIFICATIONS! For Greater BPH, Contact Us At (800) 557-4689

- 21" Wide Belt
- 15,000 BPH - 20" x 8" Cup Size
- 20,000 BPH - 20" x 8" Low Profile Cup Size
- 13"x 23" Galvanized Trunking
- Boot has 2-15/16" (2.938" Decimal Equivalent) Bearings
- Head Pulleys have 4-7/16" to 4-15/16" Double Roller Bearings
- Wide Variety of Gear Drives Offered



CATWALKS

DIMENSIONS & FEATURES

AVAILABLE IN 24' OR 12' SECTIONS

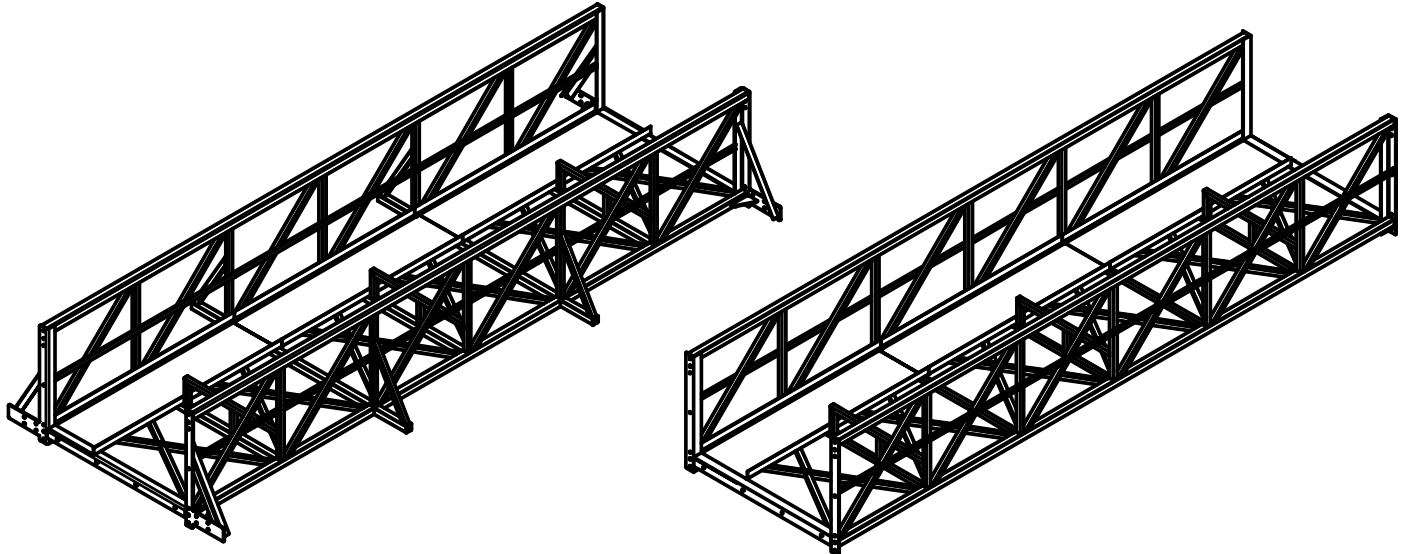

HOT DIPPED GALVANIZED FINISH

CATWALK DIMENSIONS

	A	B	C	D	E	F	WEIGHT
4x4	51.5"	48"	43"	46"	22"	24' or 12'	75 lbs/ft
4x5	51.5"	61"	54"	46"	33.5"	24' or 12'	80 lbs/ft
4x6	51.5"	79"	71"	45"	48"	24' or 12'	85 lbs/ft
4x6H	51.5"	111"	71"	45"	48"	24' or 12'	110 lbs/ft

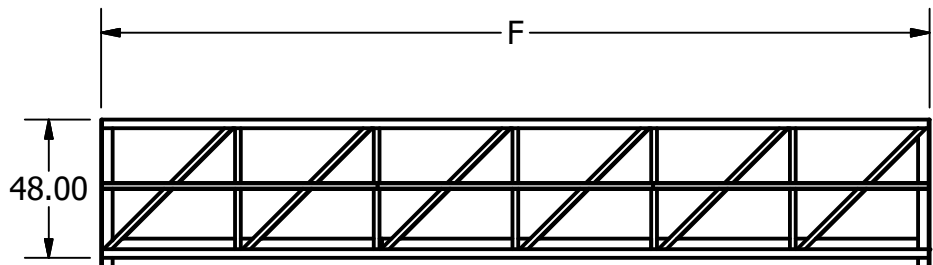
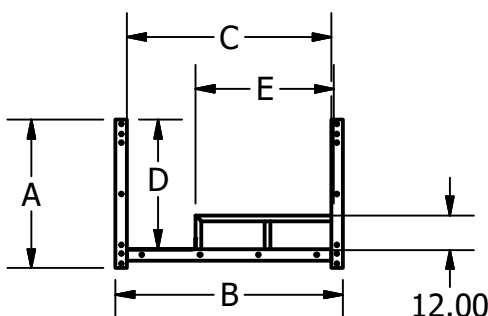
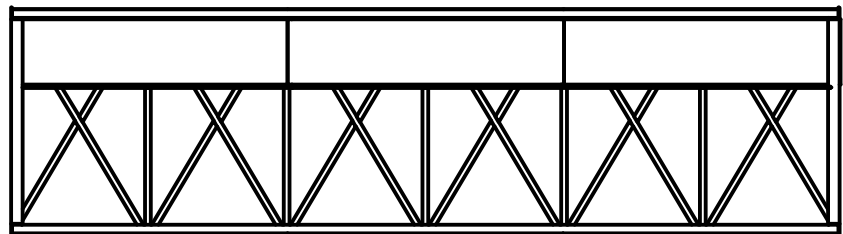
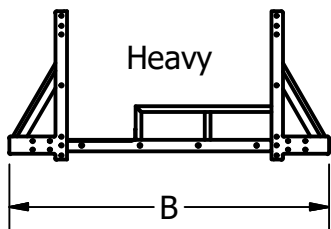

H TOWER CATWALK SUPPORT TOWER SYSTEMS

BENEFITS & FEATURES

HOT DIPPED GALVANIZED FINISH

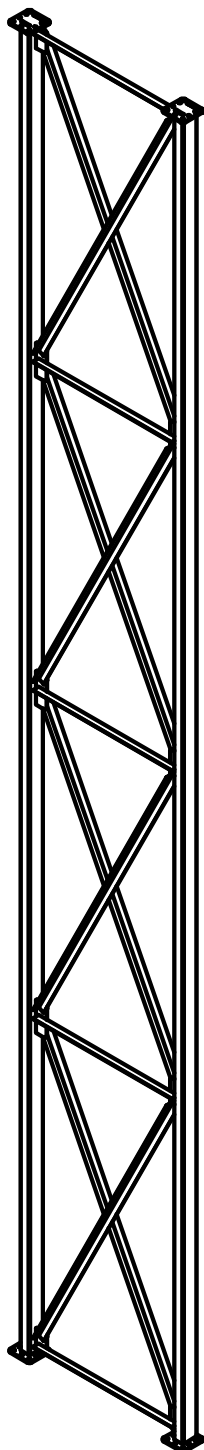
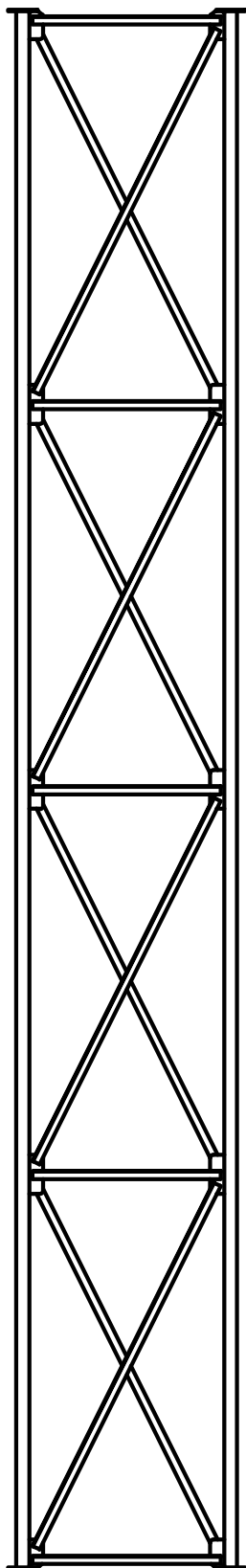

AVAILABLE
LENGTHS:
40', 20', & 10'

AVAILABLE
WIDTHS:
6', 5', & 4'

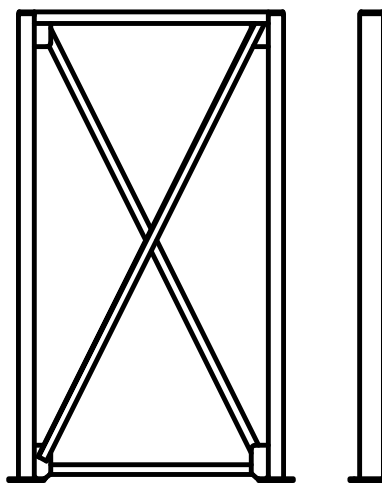
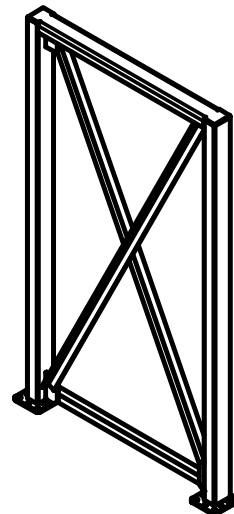

**CUSTOM
LENGTHS
AVAILABLE!**

CONVEYORS

DIMENSIONS & SPECIFICATIONS

CONVEYOR DIMENSIONS

	A	B	C	D	E	F	G	I	J	K
0810	15"	14.5"	21"	18"	9.19"	4"	10.4"	26"	8"	11"
1210	18.3"	16"	23"	20"	10.19"	5.6"	10.3"	28"	12"	15"
1214	18.75"	20"	25"	22"	11.19"	5.6"	14.25"	30.77"	12"	15"
1514	24"	20"	28"	24"	12.25"	5.6"	14.5"	31"	15.5"	18"
1918	27"	23"	32.5"	29"	14.75"	5"	18"	32.25"	19"	22"
2420	37"	25.5"	35"	32"	17.5"	5.4"	20"	40"	24"	28"

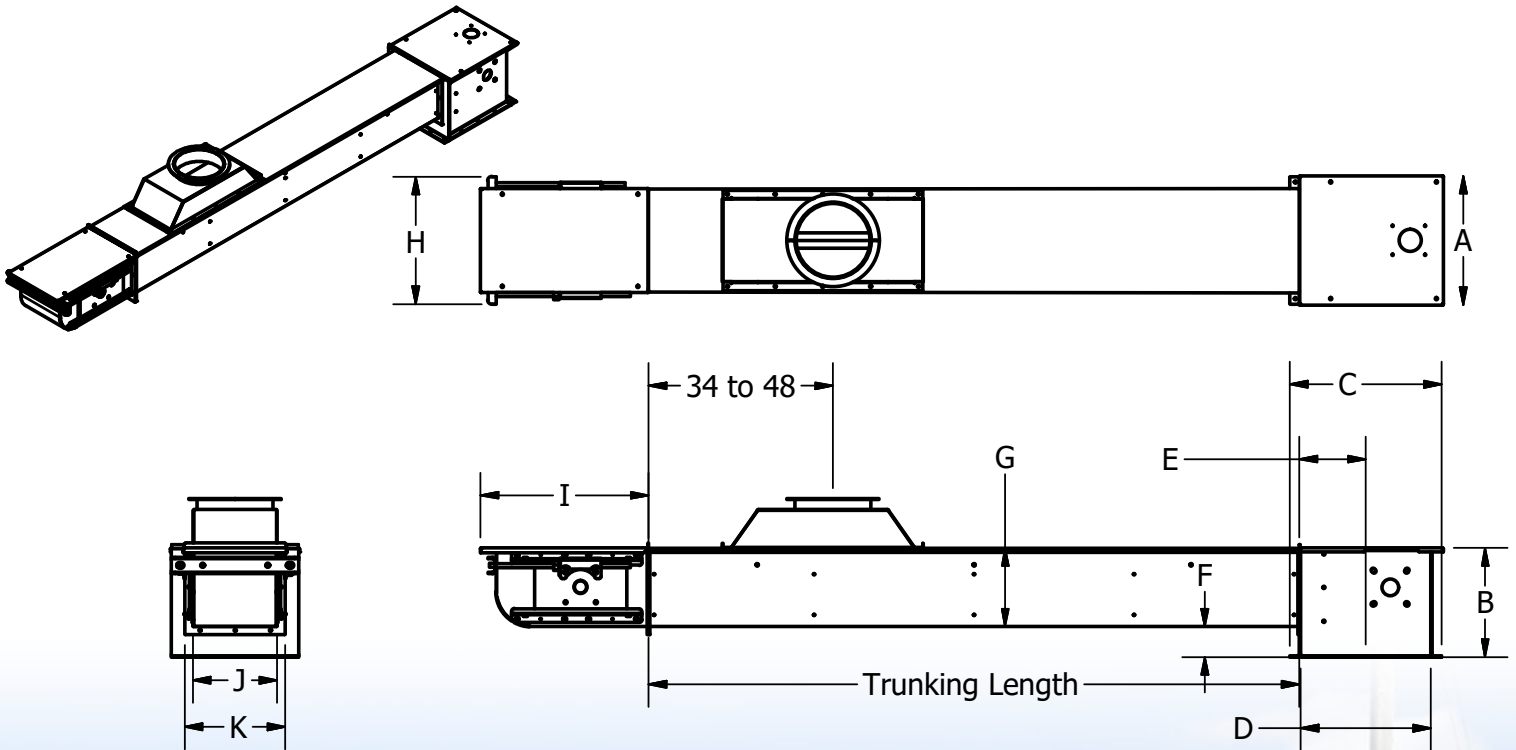



0810 CONVEYOR		3000 BPH
		<i>146 FPM – 84 RPM</i>
<i>Intermediate Length (ft)</i>	<i>Overall Length (ft)</i>	<i>HP</i>
5	9	1.5
10	14	1.5
15	19	2
20	24	3
25	29	3
30	34	3
45	49	15
50	54	15
55	59	15
60	64	15
65	69	15
70	74	15
75	79	15
80	84	15
190	194	15
195	199	15
200	204	15



0810 CONVEYOR SPECIFICATIONS

- 8" inside width by 10" side wall height
- Bolt together galvanized construction
- 3/16" head and tail sections
- 12 gauge Intermediate trough, 14 gauge cover
- 81X chain (24,000 tensile strength) with polyethylene flights on 10.5" centers
- 1.5" nylon return rollers on 30" centers
- Head and tail sections have 4 bolt flange block bearings, 9 tooth 7/8" laser cut sprockets on 1-15/16" - 2-15/16" head and tail shafts (depending on conveyor length)

CONVEYORS

SPECIFICATIONS & AVAILABLE LENGTH OPTIONS

1210 CONVEYOR SPECIFICATIONS

- 12" inside width by 10" side wall height
- Bolt together galvanized construction
- 3/16" head and tail sections
- 12 gauge Intermediate trough, 14 gauge cover
- 81X chain (24,000 tensile strength) with polyethylene flights on 10.5" centers
- 1.5" nylon return rollers on 30" centers
- Head and tail sections have 4 bolt flange block bearings, 9 tooth 7/8" laser cut sprockets on 1-15/16" - 2-15/16" head and tail shafts (depending on conveyor length)

1514 CONVEYOR SPECIFICATIONS*

- 15" inside width by 14" side wall height
- Bolt together galvanized construction
- 3/16" head and tail sections
- 12 gauge Intermediate trough, 14 gauge cover
- 81X chain (24,000 tensile strength) with polyethylene flights on 10.5" centers
- 1.5" nylon return rollers on 30" centers
- Head and tail sections have 4 bolt flange block bearings, 14 tooth 7/8" laser cut sprockets on 1-15/16" - 2-15/16" head and tail shafts (depending on conveyor length).

2420 CONVEYOR SPECIFICATIONS*

- 24" inside width by 20" side wall height
- Bolt together galvanized construction
- 3/16" head and tail sections
- 12 gauge Intermediate trough, 12 gauge cover
- WH124 HD chain with polyethylene flights on 10.5" centers
- EZ-Glide return rails
- Head and tail sections have 4 bolt flange block bearing, 12 tooth 1.5" laser cut sprockets on 2 7/16" - 4 15/16" head and tail shafts (depending on conveyor length)

1214 CONVEYOR SPECIFICATIONS*

- 12" inside width by 14" side wall height
- Bolt together galvanized construction
- 3/16" head and tail sections
- 12 gauge Intermediate trough, 14 gauge cover
- 81X chain (24,000 tensile strength) with polyethylene flights on 10.5" centers
- 1.5" nylon return rollers on 30" centers
- Head and tail sections have 4 bolt flange block bearings, 14 tooth 7/8" laser cut sprockets on 1-15/16" - 2- 7/16" head and tail shafts (depending on conveyor length)

1918 CONVEYOR SPECIFICATIONS*

- 19" inside width by 18" side wall height
- Bolt together galvanized construction
- 3/16" head and tail sections
- 12 gauge Intermediate trough, 14 gauge cover
- 81X chain (24,000 tensile strength) with polyethylene flights on 10.5" centers
- 1.5" nylon return rollers on 30" centers
- Head and tail sections have 4 bolt flange block bearings, 18 tooth 7/8" laser cut sprockets on 1-15/16" - 4-15/16" head and tail shafts (depending on conveyor length)



**Tables with length options for 1214, 1514, 1918, & 2420 Conveyors available on pages 12-15.*



1210 CONVEYOR		3500 BPH	4000 BPH	4500 BPH	5000 BPH
		<i>146 FPM – 84 RPM</i>	<i>166 FPM – 95 RPM</i>	<i>187 FPM – 107 RPM</i>	<i>208 FPM – 120 RPM</i>
Intermediate Length (ft)	Overall Length (ft)	HP	HP	HP	HP
5	9	1.5	1.5	1.5	2
10	14	1.5	1.5	2	2
15	19	2	2	3	3
20	24	3	3	3	3
25	29	3	3	3	5
30	34	3	3	5	5
35	39	3	3	5	5
40	44	3	5	5	5
45	49	3	5	5	7.5
50	54	5	5	7.5	7.5
55	59	5	5	7.5	7.5
60	64	5	7.5	7.5	7.5
65	69	5	7.5	7.5	7.5
70	74	5	7.5	7.5	10
75	79	5	7.5	7.5	10
80	84	7.5	7.5	10	10
85	89	7.5	7.5	10	10
90	94	7.5	10	10	10
95	99	7.5	10	10	10
100	104	7.5	10	10	15
105	109	7.5	10	10	15
110	114	7.5	10	10	15
115	119	10	10	10	15
120	124	10	10	10	15
125	129	10	10	15	15
130	134	10	10	15	15
135	139	10	15	15	15
140	144	10	15	15	15
145	149	10	15	15	15
150	154	15	15	15	15
155	159	15	15	15	20
160	164	15	15	15	20
165	169	15	15	15	20
170	174	15	15	15	20
175	179	15	15	20	20
180	184	15	15	20	20
185	189	15	15	20	20
190	194	15	15	20	20
195	199	15	15	20	20
200	204	15	15	20	20

CONVEYORS

AVAILABLE LENGTH OPTIONS

1214 CONVEYOR		4000 BPH	5000 BPH	6000 BPH	7000 BPH
		<i>100 FPM – 33 RPM</i>	<i>125 FPM – 41 RPM</i>	<i>150 FPM – 49 RPM</i>	<i>175 FPM – 57 RPM</i>
Intermediate Length (ft)	Overall Length (ft)	HP	HP	HP	HP
5	9	1.5	2	2	2
10	14	1.5	2	2	2
15	19	1.5	3	3	3
20	24	2	3	3	5
25	29	2	3	5	5
30	34	3	5	5	5
35	39	3	5	5	7.5
40	44	3	5	5	7.5
45	49	5	5	7.5	7.5
50	54	5	5	7.5	10
55	59	5	7.5	7.5	10
60	64	5	7.5	7.5	10
65	69	5	7.5	10	10
70	74	7.5	7.5	10	10
75	79	7.5	10	10	15
80	84	7.5	10	10	15
85	89	7.5	10	10	15
90	94	7.5	10	10	15
95	99	7.5	10	15	15
100	104	7.5	10	15	15
105	109	10	10	15	15
110	114	10	15	15	15
115	119	10	15	15	20
120	124	10	15	15	20
125	129	10	15	15	20
130	134	10	15	15	20
135	139	10	15	15	20
140	144	15	15	20	20
145	149	15	15	20	20
150	154	15	15	20	20
155	159	15	15	20	20
160	164	15	15	20	25
165	169	15	20	20	25
170	174	15	20	20	25
175	179	15	20	20	25
180	184	15	20	20	25
185	189	15	20	25	25
190	194	15	20	25	25
195	199	15	20	25	25
200	204	15	20	25	25



1514 CONVEYOR		7000 BPH	8000 BPH	9000 BPH	10,000 BPH
		<i>130 FPM – 45 RPM</i>	<i>150 FPM – 50 RPM</i>	<i>170 FPM – 55 RPM</i>	<i>182 FPM – 60 RPM</i>
Intermediate Length (ft)	Overall Length (ft)	HP	HP	HP	HP
5	9	2	3	5	5
10	14	3	5	5	5
15	19	5	5	5	5
20	24	5	5	5	5
25	29	5	5	7.5	7.5
30	34	5	7.5	7.5	7.5
35	39	7.5	7.5	7.5	10
40	44	7.5	7.5	7.5	10
45	49	7.5	7.5	10	10
50	54	7.5	10	10	10
55	59	10	10	10	15
60	64	10	10	15	15
65	69	10	15	15	15
70	74	10	15	15	15
75	79	10	15	15	15
80	84	15	15	15	20
85	89	15	15	15	20
90	94	15	15	20	20
95	99	15	15	20	20
100	104	15	20	20	20
105	109	15	20	20	20
110	114	15	20	20	25
115	119	20	20	20	25
120	124	20	20	25	25
125	129	20	20	25	25
130	134	20	20	25	25
135	139	20	25	25	25
140	144	20	25	25	
145	149	20	25	25	
150	154	20	25	25	
155	159	20	25		
160	164	25	25		
165	169	25	25		
170	174	25			
175	179	25			
180	184	25			
185	189	25			
190	194	25			
195	199	25			
200	204	25			

CONVEYORS

AVAILABLE LENGTH OPTIONS

1918 CONVEYOR		12,000 BPH	13,000 BPH	15,000 BPH
		<i>100 FPM – 33 RPM</i>	<i>125 FPM – 41 RPM</i>	<i>175 FPM – 57 RPM</i>
Intermediate Length (ft)	Overall Length (ft)	HP	HP	HP
5	9	3	3	3
10	14	3	3	5
15	19	5	5	5
20	24	5	5	7.5
25	29	7.5	7.5	7.5
30	34	7.5	7.5	10
35	39	10	10	10
40	44	10	10	15
45	49	10	10	15
50	54	15	15	15
55	59	15	15	15
60	64	15	15	20
65	69	15	20	20
70	74	20	20	20
75	79	20	20	25
80	84	20	20	25
85	89	20	20	25
90	94	20	25	25
95	99	25	25	30
100	104	25	25	30
105	109	25	25	30
110	114	25	30	30
115	119	25	30	40
120	124	30	30	40
125	129	30	30	40
130	134	30	40	40
135	139	30	40	40
140	144	40	40	40
145	149	40	40	40
150	154	40	40	50
155	159	40	40	50
160	164	40	40	50
165	169	40	40	50
170	174	40	40	50
175	179	40	50	50
180	184	40	50	50
185	189	50	50	
190	194	50	50	
195	199	50	50	
200	204	50	50	



2420 CONVEYOR		18,000 BPH	20,000 BPH
		<i>100 FPM – 33 RPM</i>	<i>150 FPM – 49 RPM</i>
Intermediate Length (ft)	Overall Length (ft)	HP	HP
5	9	10	10
10	14	10	10
15	19	10	10
20	24	10	10
25	29	15	15
30	34	15	15
35	39	15	15
40	44	20	20
45	49	20	20
50	54	20	25
55	59	20	25
60	64	25	25
65	69	25	30
70	74	25	30
75	79	30	40
80	84	30	40
85	89	30	40
90	94	40	40
95	99	40	40
100	104	40	40
105	109	40	50
110	114	40	50
115	119	40	50
120	124	50	50
125	129	50	50
130	134	50	60
135	139	50	60
140	144	50	60
145	149	50	60
150	154	60	60
155	159	60	75
160	164	60	75
165	169	60	75
170	174	60	75
175	179	60	75
180	184	75	75
185	189	75	75
190	194	75	75
195	199	75	
200	204	75	

INCLINED CONVEYORS

DIMENSIONS & SPECIFICATIONS

INCLINED CONVEYOR DIMENSIONS

	A	B	C	D	E	F	G	H
1213	22"	16.4"	20"	28"	12"	15"	19"	13"
1219	26"	24.75"	26"	23"	12"	15"	19"	19"
1621	36"	27"	34"	38"	16"	19"	23.5"	21"
2021	32"	27"	26"	29.5"	21"	25"	30"	20"
2126	36.6"	35"	32"	36"	22"	26"	30"	26"
2630	46.5"	38"	44"	34"	26"	30"	36"	30"
3038	48"	40"	46"	38"	30"	34"	40"	34"

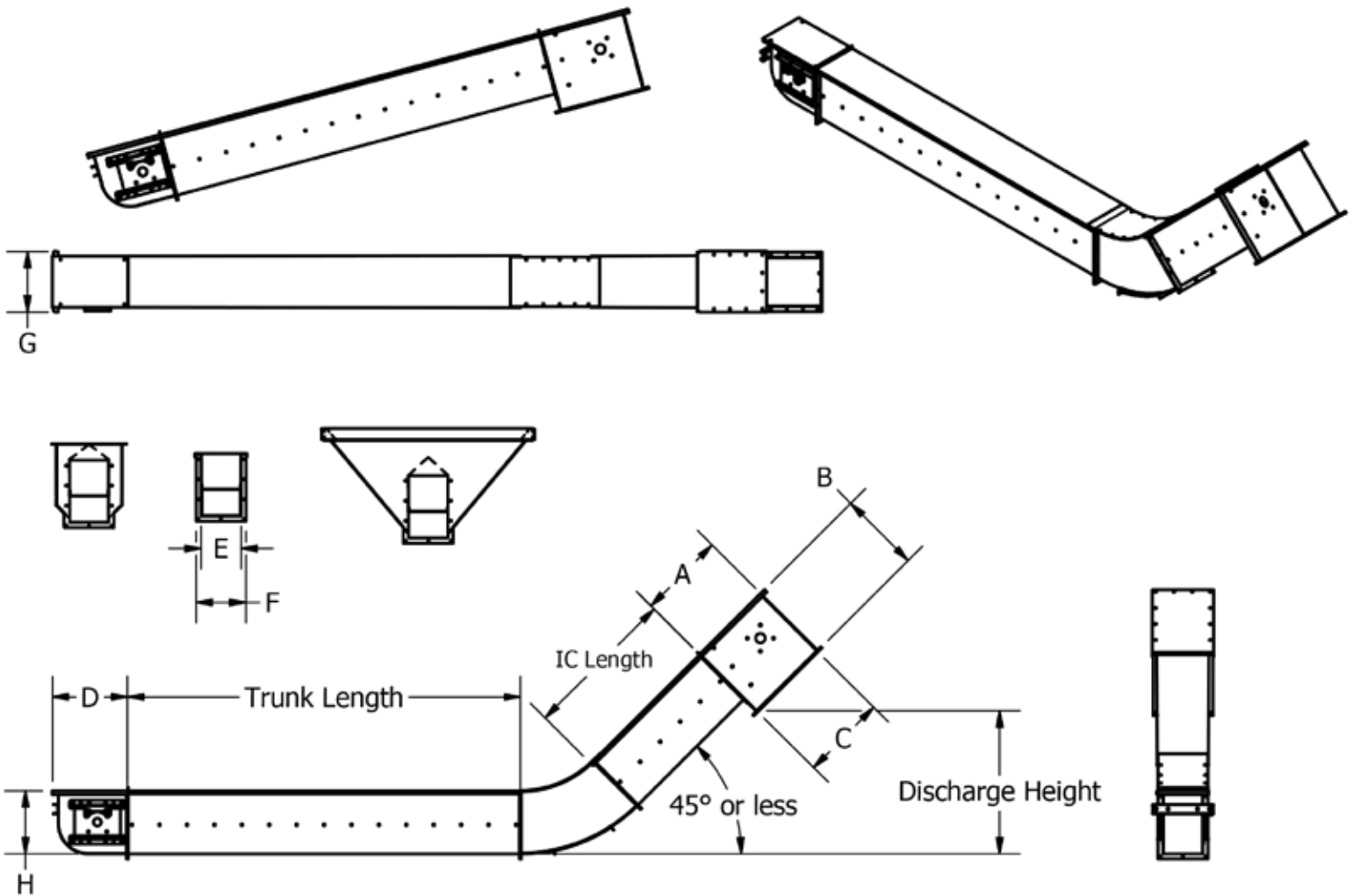



1213 INCLINED CONVEYOR

Head & Tail Assemblies			
CAPACITY		CLASS 2	
BPH	HP	Drive	Weight (lbs)
1,500	2	TA1	779
1,500	3	TA1	779
1,500	5	TA2	835
1,500	7.5	TA3	922
1,500	10	TA3	922
1,500	15	TA4	1076
1,500	20	TA5	1268
1,500	25	TA5	1268
2,200	2	TA1	779
2,200	3	TA1	779
2,200	5	TA2	835
2,200	7.5	TA3	922
2,200	10	TA3	922
2,200	15	TA4	1076
2,200	20	TA5	1268
2,200	25	TA5	1268
3,000	2	TA1	779
3,000	3	TA1	779
3,000	5	TA2	835
3,000	7.5	TA3	922
3,000	10	TA3	922
3,000	15	TA4	1,076
3,000	20	TA5	1,268
3,000	25	TA5	1,268

1213 INCLINED CONVEYOR SPECIFICATIONS

- 12" inside width by 13" side wall height
- Bolt together galvanized construction
- 3/16" head and tail sections
- 12 gauge Intermediate trough, 14 gauge cover
- 81X chain (24,000 tensile strength) with polyethylene flights on 10.5" centers
- 1.5" nylon returns on intermediate floor
- Head and tail sections have 4 bolt flange block bearings, 9 tooth 7/8" laser cut sprockets on 1-15/16" - 2-15/16" head and tail shafts (depending on conveyor length)

1219 INCLINED CONVEYOR

Head & Tail Assemblies			
CAPACITY		CLASS 2	
BPH	HP	Drive	Weight (lbs)
3,100	2	TA1	850
3,100	3	TA1	850
3,100	5	TA2	910
3,100	7.5	TA3	998
3,100	10	TA4	1210
3,100	15	TA5	1392
3,100	20	TA5	1392
3,100	25	TA6	1672
4,000	2	TA1	850
4,000	3	TA1	850
4,000	5	TA2	910
4,000	7.5	TA3	922
4,000	10	TA3	998
4,000	15	TA4	1210
4,000	20	TA5	1392
4,000	25	TA5	1392
5,000	2	TA1	850
5,000	3	TA1	850
5,000	5	TA2	910
5,000	7.5	TA2	910
5,000	10	TA3	998
5,000	15	TA4	1,210
5,000	20	TA5	1,392
5,000	25	TA5	1,392

1219 INCLINED CONVEYOR SPECIFICATIONS

- 12" inside width by 19" side wall height
- Bolt together galvanized construction
- 3/16" head and tail sections
- 12 gauge Intermediate trough, 14 gauge cover
- 81X H chain (24,000 tensile strength) with polyethylene flights on 10.5" centers
- 1.5" nylon returns on intermediate floor
- Head and tail sections have 4 bolt flange block bearings, 14 tooth 7/8" laser cut sprockets on 1-15/16" - 2-15/16" head and tail shafts (depending on conveyor length)

INCLINED CONVEYORS

AVAILABLE CAPACITY OPTIONS

1621 INCLINED CONVEYOR

Head & Tail Assemblies

CAPACITY		CLASS 2	
BPH	HP	Drive	Weight (lbs)
5,000	2	TA1	865
5,000	3	TA1	865
5,000	5	TA2	920
5,000	7.5	TA3	1050
5,000	10	TA4	1180
5,000	15	TA5	1385
5,000	20	TA5	1385
5,000	25	TA6	1682
6,800	2	TA1	865
6,800	3	TA1	865
6,800	5	TA2	920
6,800	7.5	TA3	1,050
6,800	10	TA3	1,050
6,800	15	TA4	1,180
6,800	20	TA5	1,385
6,800	25	TA5	1,385

1621 INCLINED CONVEYOR SPECIFICATIONS

- 16" inside width by 21" side wall height
- Bolt together galvanized construction
- 1/4" head and tail sections, 10 gauge Intermediate trough, 12 gauge cover
- 81XXH chain (44,000 tensile strength) with polyethylene flights on 10.5" centers
- 1.5" nylon returns on intermediate floor
- Head and tail sections have 4 bolt flange block bearings, 14 tooth 7/8" laser cut sprockets on 1-15/16" - 3 7/16" head and tail shafts (depending on conveyor length)

2021 INCLINED CONVEYOR

Head & Tail Assemblies

CAPACITY		CLASS 2	
BPH	HP	Drive	Weight (lbs)
7,500	3	TA1	650
7,500	5	TA2	695
7,500	7.5	TA3	785
7,500	10	TA4	952
7,500	15	TA4	952
7,500	20	TA5	1195
7,500	25	TA5	1195
8,500	3	TA1	650
8,500	5	TA2	695
8,500	7.5	TA3	785
8,500	10	TA3	785
8,500	15	TA4	952
8,500	20	TA5	1,195
8,500	25	TA5	1,195

2021 INCLINED CONVEYOR SPECIFICATIONS

- 20" inside width by 21" side wall height
- Bolt together galvanized construction
- 1/4" head and tail sections, 10 gauge Intermediate trough, 12 gauge cover
- 81XXH chain (44,000 tensile strength) with polyethylene flights on 10.5" centers
- 1.5" nylon returns on intermediate floor
- Head and tail sections have 4 bolt flange block bearings, 14 tooth 7/8" laser cut sprockets on 1-15/16" - 2-15/16" head and tail shafts (depending on conveyor length)

2126 INCLINE CONVEYOR Head & Tail Assemblies	CAPACITY		CLASS 2	
	BPH	HP	Drive	Weight (lbs)
	10,000	15	TA5	2,150
	10,000	20	TA6	2,345
	10,000	25	TA6	2,345
	10,000	30	TA7	2,650
	10,000	40	TA8	2,870
	10,000	50	TA8	2,870
	12,500	15	TA5	2,150
	12,500	20	TA5	2,150
	12,500	25	TA6	2,345
	12,500	30	TA7	2,650
	12,500	40	TA7	2,650
	12,500	50	TA8	2,870

2126 INCLINED CONVEYOR SPECIFICATIONS

- 21" inside width by 26" side wall height
- Bolt together galvanized construction
- 1/4" head and tail sections
- 10 gauge Intermediate trough, 12 gauge cover
- 81XX H chain (44,000 tensile strength) with polyethylene flights on 10.5" centers
- 1.5" nylon returns on intermediate floor
- Head and tail sections have 4 bolt flange block bearings, 19 tooth 7/8" laser cut sprockets on 1-15/16" - 2-15/16" head and tail shafts (depending on conveyor length)



2630 INCLINED CONVEYOR

Head & Tail Assemblies

CAPACITY		CLASS 2	
BPH	HP	Drive	Weight (lbs)
15,000	15	TA5	2,150
15,000	20	TA6	2,450
15,000	25	TA7	2,760
15,000	30	TA7	2,760
15,000	40	TA8	2,866
15,000	50	TA9	3,480
15,000	60	TA9	3,480
15,000	75	TA10	4,025
17,500	15	TA5	2,150
17,500	20	TA6	2,450
17,500	25	TA7	2,760
17,500	30	TA7	2,760
17,500	40	TA8	2,866
17,500	50	TA8	2,866
17,500	60	TA9	3,480
17,500	75	TA10	4,025

2630 INCLINED CONVEYOR SPECIFICATIONS

- 26" inside width by 30" side wall height
- Bolt together galvanized construction
- 1/4" head and tail sections
- 10 gauge Intermediate trough, 12 gauge cover
- WH124 chain (77,000 tensile strength) with polyethylene flights on 10.5" centers
- 1.5" nylon returns on intermediate floor
- Head and tail sections have 4 bolt flange block bearings, 18 tooth 7/8" laser cut sprockets on 1-15/16" - 3-15/16" head and tail shafts (depending on conveyor length)

3038 INCLINED CONVEYOR

Head & Tail Assemblies

CAPACITY		CLASS 2	
BPH	HP	Drive	Weight (lbs)
20,000	15	TA6	4,395
20,000	20	TA7	4,785
20,000	25	TA8	4,895
20,000	30	TA8	4,895
20,000	40	TA9	5,525
20,000	50	TA10	6,285
20,000	60	TA10	6,285
20,000	75	TA12	7,585
25,000	15	TA6	4,395
25,000	20	TA7	4,785
25,000	25	TA7	4,785
25,000	30	TA8	4,895
25,000	40	TA8	4,895
25,000	50	TA9	5,525
25,000	60	TA10	6,285
25,000	75	TA10	6,285

3038 INCLINED CONVEYOR SPECIFICATIONS

- 30" inside width by 38" side wall height
- Bolt together galvanized construction
- 1/4" head and tail sections
- 10 gauge Intermediate trough, 12 gauge cover
- WH124 chain (77,000 tensile strength) with polyethylene flights on 10.5" centers
- 1.5" nylon returns on intermediate floor
- Head and tail sections have 4 bolt flange block bearings, 24 tooth 1 1/2" laser cut sprockets on 2-15/16" - 4-15/16" head and tail shafts (depending on conveyor length)





196 ½ E. 6th St. • Sioux Falls, SD • 1-800-557-4689 • www.siouxsteel.com



19
SINCE
18

Since 1918, Sioux Steel Company is now in its fourth generation as a family-owned company. Based in Sioux Falls, South Dakota, we know the agricultural industry and know that you need high-quality, dependable products. Our mission continues to be not only to satisfy our customers, but we want them to be *delighted* to do business with us.

Interested in working for Sioux Steel Company? Scan this QR Code with your smartphone to e-mail us for our current employment opportunities.

