

OWNER'S MANUAL

MANUAL NO. 665376

8/8/00

KOYKER[®]

155

LOADER

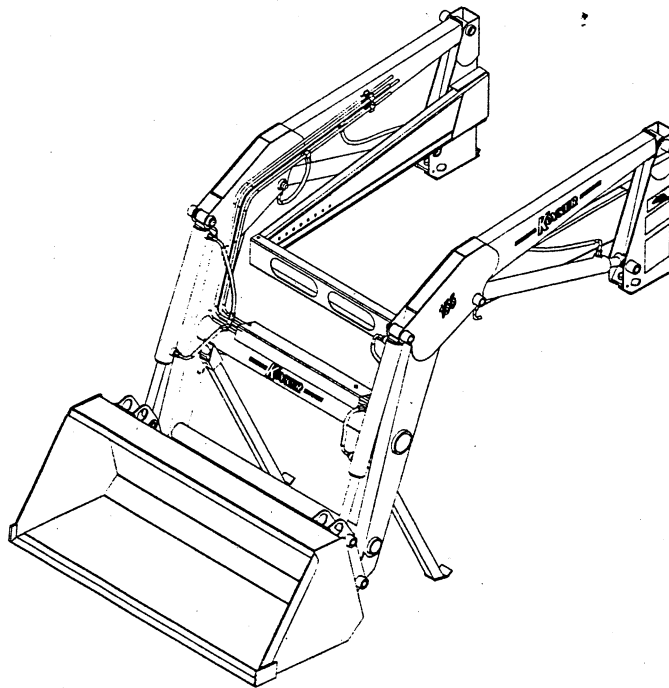

**IMPORTANT-KOYKER DEALER
BE SURE THIS MANUAL IS GIVEN TO THE
PURCHASER FOR FUTURE REFERENCE
KOYKER MFG. CO., P.O. BOX 409, LENNOX, SD., 57039
LENNOX, SD 57039**

CONTENTS

CONTENTS	PAGE
Introduction	1
Safety Alert Symbol.....	2
Specifications.....	3
Safety Information	4 - 6
Safety Labels	7 - 8
Attaching Loader	9
Operation	10
Detaching Loader	11
Loader Inspection, Lubrication, and Maintenance	12
Hydraulic System Parts List.....	13
Hydraulic System Parts Diagram.....	14
“155” Loader Parts Diagram	15
Parts Identification Schedule	16 - 17
Warranty	18
Cylinder Warranty	19
Hydraulic Cylinders Information.....	20
1 3/4” Cylinder Service Kit	21
2” Cylinder Service Kit	22
Cylinder Parts List.....	23
Cylinder Parts Diagram	24
Piston and Gland Diagram	25
Dinoil Valve Hookup.....	26

INTRODUCTION

For years, Koyker Manufacturing Company of Lennox, South Dakota, has provided the loader industry with innovative ideas for a more efficient and dependable means of material handling. Now, with the increasing popularity of the MFWD (Mechanical Front Wheel Drive) tractors, Koyker has again met the challenge and provided the market with a loader that will allow the efficient use of these tractors in material handling. The KOYKER 155 Loader provides you with state-of-the-art design and innovation for your handling chores.

Features such as quality construction, ease of maintenance, and high performance operating capacities, all at a low price, make the new 155 Loader one of the most efficient loaders ever. With proper care and handling, it will provide many years of dependable service.

This manual is designed to provide you with important information regarding the basic loader and bucket. Our sincere intent, in providing this manual, is to help you or those involved better understand the machine and to prevent accidents.

Should you have any questions, comments, improvements, or suggestions regarding the contents of any of the manuals provided, please contact Koyker Manufacturing Company.

We care about your safety!

Remember ALL safety decals are no charge from the factory. Please replace all safety decals.

SAFETY ALERT SYMBOL

The symbol shown below is used to call your attention to instructions concerning your personal safety. Watch for this symbol, it points out important safety precautions. It means **ATTENTION! Become Alert! Your Personal Safety Is Involved!**

Read the message that follows and be alert to the possibility of personal injury or death.

DANGER: Indicates an imminently hazardous situation that, if not avoided, will result in death or serious injury.

WARNING: Indicates a potentially hazardous situation that, if not avoided, could result in death or serious injury.

CAUTION: Indicates a potentially hazardous situation that, if not avoided may result in minor or moderate injury.



WARNING!

Anyone who will operate or work around a front-end loader should **first** read this manual.

SAFETY

Improper use of a loader can cause serious injury or death. The following safety precautions, and those given on the tractor mount installation instructions, should be thoroughly understood before attempting to operate this machine.

BEFORE OPERATING:

Carefully study and understand this manual, the specific tractor mount instructions, and the attachment(s) manual(s).

Prior to operation, inspect the loader for system leaks and damaged, missing, or malfunctioning components in an effort to avoid the possibility of a dangerous failure involving structural members or hydraulic system components.

Be certain any repairs necessary are completed prior to loader operation.

Follow recommended maintenance procedures and precautions on Page 12.

Completely familiarize yourself and others involved with the operation of the hydraulic control valve before operating the loader.

Be certain all bystanders are clear of the machine and operation area prior to operation.

It may be necessary to add wheel ballast or rear weights as recommended by the tractor manufacturer to maintain stability of the machine to prevent tipping or upset which could result in serious injury or death. See mounting instructions for specific information.

It is recommended that both front and rear wheel treads be set to the widest recommended width to prevent tipping or upset which could result in serious injury or death.

This loader is designed for farm type operations such as snow removal, barn and feedlot cleaning or light grading and digging. It's design is **NOT** intended for commercial and /or industrial use.

DURING OPERATION:

Never operate the machine other than from the tractor operator's seat.

Be sure operating area is clear of others during machine operations.

Never lift, hoist, or carry humans in the bucket or on any portion of the loader or loader attachments. Failure to heed, may result in serious injury or death.

SAFETY CONTINUED

Transport the machine load at the slowest speed possible and with the loader boom at the lowest transport position to avoid tipping or upsetting, which may result in serious injury or death.

Be extremely careful when working on inclines or near loose fill, rocks, and holes as they can cause tipping or upsetting which may result in serious injury or death.

Be certain to avoid overhead electrical wires when operating loader. Contact with power lines may cause serious injury or death.

Avoid sudden stops when lowering or lifting the loader boom to prevent loss of control over the machine and/or load, which may result in serious injury or death.

Use maximum ballast and the widest recommended wheel setting on your tractor when handling large shiftable loads.

Never attempt to ram with the bucket at high speed or full tractor power. Sudden impact may result in structural failure and possible serious injury or death.

Never adjust or perform maintenance on the loader or tractor with the unit in motion, or without power source locked out.

Never get under bucket or lift arms or reach through the lift arms or bucket linkage when the loader is in operation. Inadvertent movement may cause serious injury or death.

FOLLOWING OPERATION:

Whenever the machine is not in operation, lower the loader boom and set the tractor brakes, disengage drive, shut the engine off, and remove the ignition key before dismounting the tractor.

If loader is to be disengaged from tractor, be sure the loader is securely supported on a hard, level surface and the stand is securely engaged. Be certain all connections between tractor and loader are free before disengaging.

TRANSPORTING:

Use safety lights and SMV emblem in addition to whatever local codes require when equipment is being transported on the road or highway. Check with proper authorities for legal limitations.

Transport all loads at a slow and safe speed.

Carry the load as low as possible and maintain adequate visibility and good round clearance at all times.

SAFETY CONTINUED

PERFORMING MAINTENANCE:

Carefully review, understand, and follow the “maintenance” section in this owner’s manual before attempting to service loader.

Lower the bucket or attachment to the ground, shut off tractor engine, and relieve pressure in the hydraulic system before adjusting, lubricating, or servicing the loader.

Escaping hydraulic oil under pressure can penetrate the skin. Never use any part of your body to check for hydraulic leaks. Use cardboard when checking for leaks. See Fig. 1-1. Relieve hydraulic pressure before disconnecting any hydraulic line. Failure to heed may result in serious injury or death.

Before disconnecting hydraulic lines, lower the loader and attachments. Lock out the hydraulic supply and relieve all hydraulic pressure.

Replace any damaged or painted-over decals. See Page 8 & 9 for replacement decals.

REMEMBER:

1. Move Slowly!
2. Always use care and common sense!
3. Be careful for your own sake and for that of others!

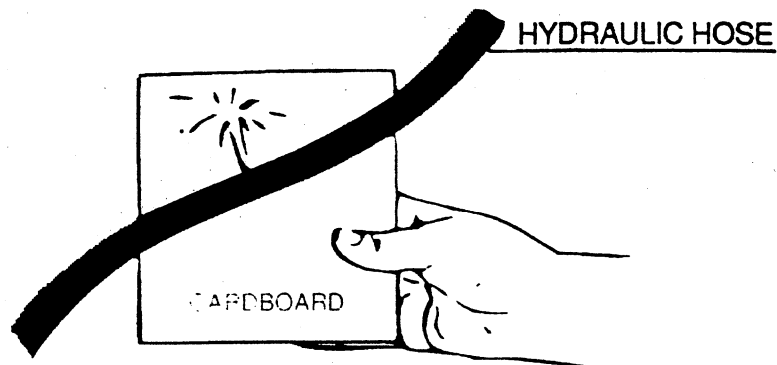

FIG. 1-1

SAFETY DECALS



CAUTION

Serial Number _____

DO NOT OPERATE LOADER WITHOUT FIRST READING OPERATORS MANUAL.

OPERATE LOADER FROM TRACTOR SEAT ONLY.

MOVE AND TURN TRACTOR AT LOW SPEEDS.

LOWER LOADER ARMS WHEN PARKING OR SERVICING.

CARRY LOADER ARMS AT A LOW POSITION DURING TRANSPORT.

ADD RECOMMENDED WHEEL BALLAST OR REAR WEIGHT FOR STABILITY.

MOVE WHEELS TO WIDEST SETTING RECOMMENDED FOR STABILITY.



This symbol means caution! Stay Alert! Watch for it!

**KOYKER MANUFACTURING CO.
P.O. BOX 409, 200 N. CLEVELAND
LENNOX, SD 57039**

ASAE R355

! WARNING

**HYDRAULIC OIL UNDER PRESSURE
CAN PENETRATE THE SKIN!**

- **NEVER USE ANY PART OF YOUR BODY TO CHECK FOR LEAKS IN HYDRAULIC LINES.**
- **IF YOU SUSPECT YOU HAVE A LEAK IN YOUR LINES ALWAYS USE CARDBOARD TO CHECK.**
- **BE SURE TO ALWAYS RELIEVE HYDRAULIC PRESSURE BEFORE DISCONNECTING LINES.**

**FAILURE TO HEED WILL RESULT
IN SERIOUS INJURY OR DEATH!**

661015

02-0360

SAFETY DECALS

CAUTION

LIFTING OBJECTS

- 1. USE OF FRONT LOADERS FOR HANDLING HEAVY OBJECTS SUCH AS LARGE ROUND OR RECTANGULAR BALES, LARGE BALES, LOGS, DRUMS, ETC. IS NOT RECOMMENDED.**
- 2. HANDLING LARGE HEAVY OBJECTS CAN BE EXTREMELY DANGEROUS DUE TO:**
 - DANGER OF ROLLING THE TRACTOR OVER.**
 - DANGER OF UP-ENDING THE TRACTOR.**
- 3. DANGER OF THE OBJECT ROLLING OR SLIDING DOWN THE LOADER ARMS ONTO THE OPERATOR.**

IF YOU MUST PERFORM THIS TYPE OF WORK, PROTECT YOURSELF BY:

- NEVER LIFTING HIGHER THAN NECESSARY TO CLEAR THE GROUND WHEN MOVING.**
- BALLAST TRACTOR REAR TO COMPENSATE FOR LOAD.**
- NEVER LIFT OBJECTS WITHOUT ADEQUATE ANTI-ROLLBACK GUARDING.**
- ALWAYS MOVE SLOWLY AND CAREFULLY. AVOID ROUGH TERRAIN.**

ATTACHING THE LOADER



IMPORTANT:

Never attempt loader attachment on grades which are not reasonably level.

1. Check to be sure that the top surface of both mounting shoes are free of bolts, screws or other obstructions.
2. Drive the tractor slowly and carefully in between the loader arms only far enough to permit hook-up of the hydraulic system hoses.
3. Once all hoses have been properly coupled, drive the tractor forward checking to insure that the bottom of each upright clears the mount shoes.
4. To allow the upright base to settle into the mount shoe, tip the bucket down slowly. After the upright contacts the shoe, engage the upright anchor bar into the rear of the shoe by driving the tractor ahead slowly.
5. To secure the loader, install the 661983 - 3/4" diameter pins. Tighten the 3/4" diameter bolt on the front of the upright to draw the upright to the rear of the shoe.
6. After both uprights are secured to the shoes, raise the loader slowly to disengage and store the loader stand.
7. Prior to operation, be certain to review all safety and operation information contained within this manual.

OPERATION



WARNING:

Never allow anyone to operate the loader until they have carefully reviewed and understood this owner's manual.

FILLING THE BUCKET:

Approach and enter the pile with the bucket level.

Roll bucket back gradually as the loader moves through the pile.

RAISING THE BUCKET:



WARNING:

Make sure material in bucket cannot spill out on to tractor when loader boom is raised. Keep clear of overhead obstructions such as trees, limbs or power lines when raising the bucket.

Side cutting is the best method of reducing large stockpiles. If the sides of the pile are too high, use the loader to pull them down and reduce the possibility of slides.



WARNING:

NEVER attempt to operate the loader with someone near the loader frame or bucket.

DETACHING THE LOADER



IMPORTANT:

Never attempt loader detachment on grades which are not reasonably level.

1. Raise loader frame slightly to permit loader stand storage.
2. Lower loader and tip bucket slightly forward to apply pressure to mount connection. **NOTE:** This will prevent the loader from inadvertently rocking forward when the attachment screws are removed.
3. Loosen the 3/4" bolt on the front of both uprights and remove the 661983 - 3/4" diameter locking pin
4. Carefully, and very slowly, back out far enough to permit separation of the upright anchor. **NOTE:** Should the loader move when tractor is backed up, try rotating the bucket up or down.
5. Before completely backing out, disconnect and store the loader system hydraulic hoses. It is important that the hoses be properly stored to keep the hose couplers as clean as possible.

IMPORTANT:

Never store the detached loader where insufficient soil bearing capacity exists. Good firm clay or firmly packed dirt are sufficient, providing the area is dry. If you are unsure, use blocking under the stand foot to disperse the load. Failure to heed, may allow the loader to settle and prevent attachment at later date.



WARNING:

Re-couple any hydraulic hose together for your particular hydraulic system when necessary to prevent damage to tractor hydraulics. See your particular mount or hydraulic hook-up instructions.

LOADER INSPECTION, LUBRICATION, AND MAINTENANCE

Lower the bucket to the ground, shut off tractor engine, and relieve the pressure in the hydraulic system before adjusting, lubricating, or servicing the loader.

Inspect all pins and grease fittings before each use and lubricate with heavy duty grease as indicated in this manual.

Periodically check all bolts for looseness and retorque if necessary.

Before storage, be certain all hydraulic cylinders are fully collapsed so that the rod will not be exposed to the elements or damaged.

Be certain hydraulic system remains sealed at all times to prevent contamination.

Check and maintain an adequate fluid level in the tractor reservoir prior to use.

Inspect all hydraulic system hoses and fittings. Replace prior to further operation if damaged.



WARNING:

Escaping hydraulic oil under pressure can penetrate the skin. Never use any part of your body to check for hydraulic leaks. Use cardboard when checking for leaks. See Fig. 1. Relieve hydraulic pressure before disconnecting any hydraulic line. Failure to heed may result in serious injury or death.

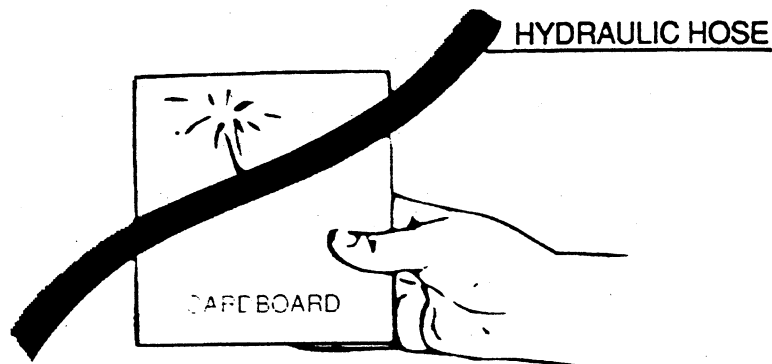

FIG. 1-1

HYDRAULIC SYSTEM PARTS LIST

KEY	PART NUMBER	DESCRIPTION	QUANTITY
1.....	655615.....	1st Oil Line	1
2.....	655616.....	2nd Oil Line	1
3.....	655617.....	3rd Oil Line	1
4.....	655618.....	4th Oil Line	1
5.....	660803.....	2" Lift Cylinder.....	2
6.....	660804.....	2" Bucket Cylinder.....	2
7.....	655179.....	12" Hydraulic Hose.....	2
8.....	655180.....	22" Hydraulic Hose.....	2
9.....	667776.....	16" Hydraulic Hose.....	4

OPTIONAL CYLINDERS

9.....	665580.....	1 3/4" Lift Cylinder.....	2
10.....	665590.....	1 3/4" Bucket Cylinder	2

HYDRAULIC SYSTEM PARTS DIAGRAM

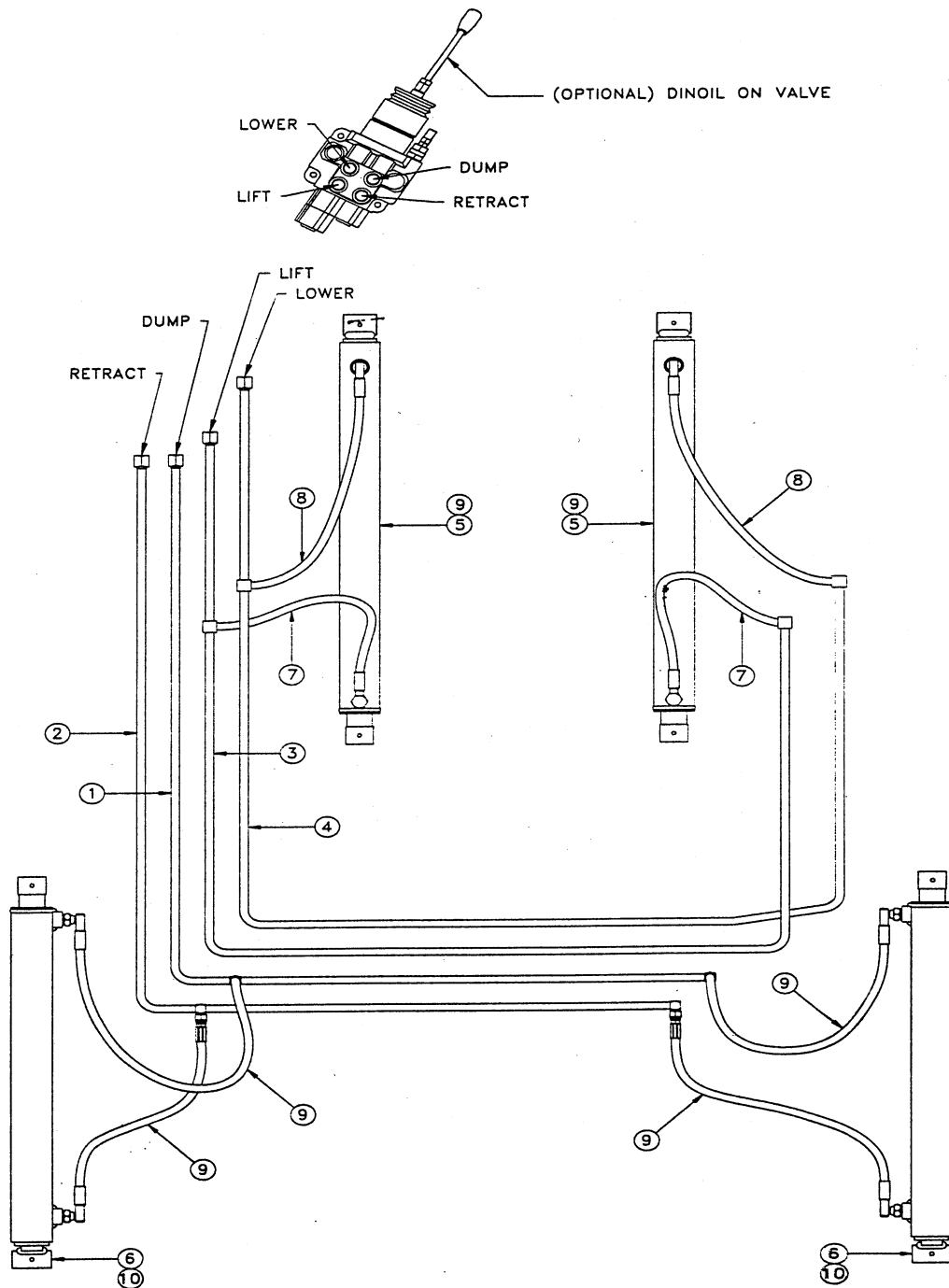

KOYKER "155" LOADER PARTS DIAGRAM

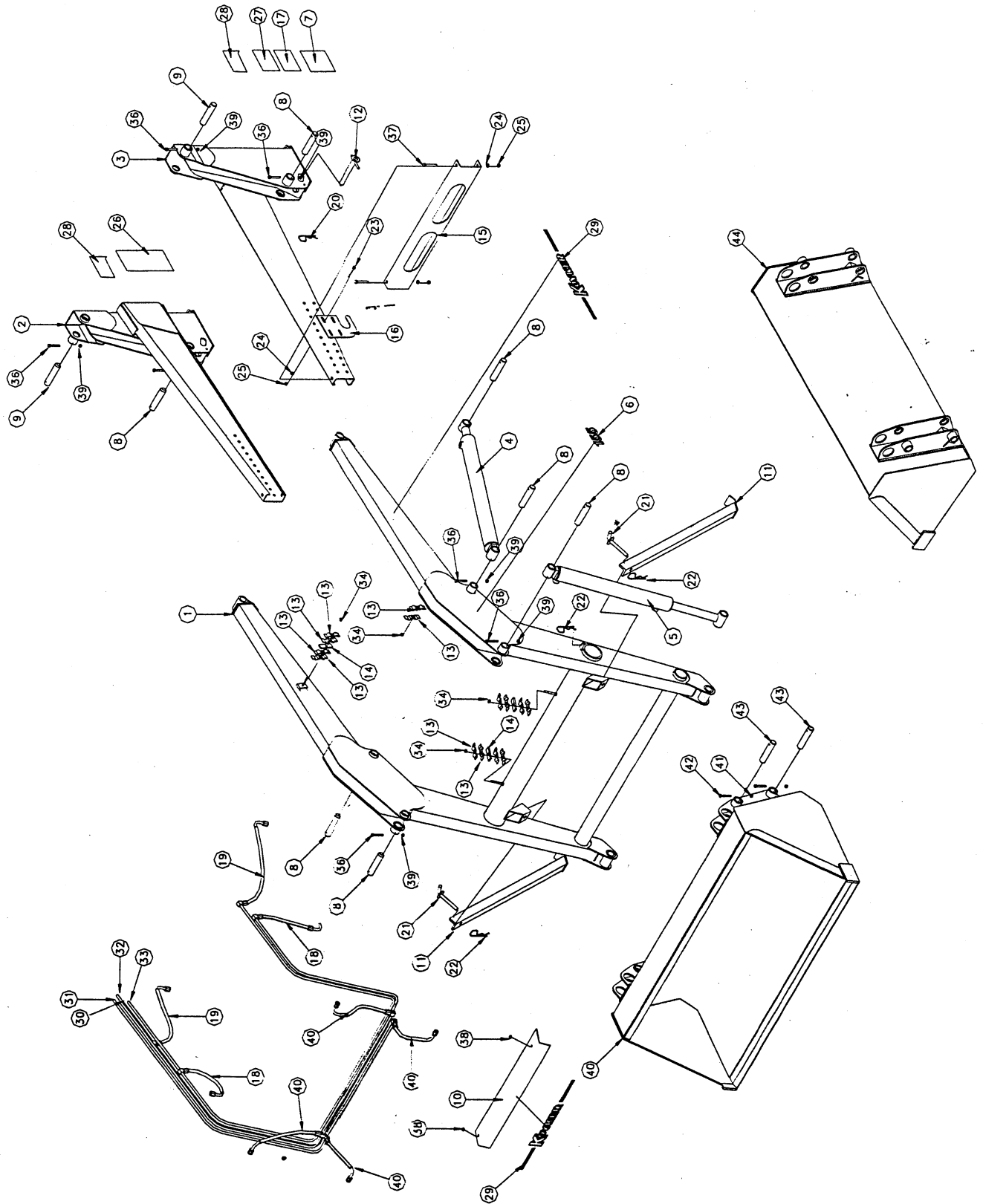

PARTS IDENTIFICATION SCHEDULE

KEY	PART NUMBER	DESCRIPTION	QUANTITY
1.....	660800.....	Main Frame.....	1
2.....	660801.....	RH Upright.....	1
3.....	660802.....	LH Upright.....	1
4.....	660803.....	2" Lift Cylinder.....	2
5.....	660804.....	2" Bucket Cylinder.....	2
6.....	660805.....	"155" Decal.....	2
7.....	660806.....	Serial Number Plate.....	1
8.....	660807.....	4 5/8" Pivot Pin.....	6
9.....	660808.....	5 1/4" Pivot Pin.....	2
10.....	660809.....	Oil Line Cover.....	1
11.....	660810.....	Stand.....	2
12.....	661983.....	Mount Pin.....	2
13.....	661997.....	Oil Line Clamp.....	14
14.....	661998.....	Oil Line Spacer.....	3
15.....	661999.....	Crossmember.....	1
16.....	662000.....	Wrap Arm Clip.....	2
17.....	665247.....	Nitro Steel Decal.....	1
18.....	655179.....	12" Hydraulic Hose.....	2
19.....	655180.....	22" Hydraulic Hose.....	2
20.....	640246.....	#6 Hitch Pin.....	2
21.....	641119.....	Lock Pin.....	2
22.....	640671.....	#3 Hitch Pin.....	4
23.....	640028.....	HH Cap Screw; 3/8" x 1".....	8
24.....	640153.....	Lockwasher; 3/8".....	10
25.....	640132.....	Hex nut; 3/8".....	10
26.....	663314.....	"Caution Lifting Object" Decal.....	1
27.....	661015.....	"Warning Hydraulic Oil Pressure" Decal.....	1
28.....	654629.....	"American Made" Decal.....	2
29.....	654632.....	"KOYKER" Decal.....	2
30.....	655615.....	1st Oil Line.....	1
31.....	655616.....	2nd Oil Line.....	1
32.....	655617.....	3rd Oil Line.....	1
33.....	655618.....	4th Oil Line.....	1
34.....	640128.....	Locknut; 5/16".....	4
35.....	640154.....	Flatwasher; 3/8".....	8
36.....	651703.....	HH Cap Screw; 1/4" x 2".....	8
37.....	652039.....	HH Cap Screw; 3/8" x 5".....	2
38.....	652360.....	Hex nut; 5/16".....	2
39.....	640126.....	Locknut; 1/4".....	8
40.....	657776.....	16" Hydraulic Hose.....	4

PARTS IDENTIFICATION CONTINUED

Optional Buckets & Cylinders

KEY	PART NUMBER	DESCRIPTION	QUANTITY
-	665295	4' Bucket Bundle	
40.....	665300.....	4' Bucket Weldment	1
41.....	640126.....	1/4" Locknut	4
42.....	651703.....	HH Cap Screw; 1/4" x 2"	4
43.....	660808.....	Pivot Pin.....	4
-	665296	5' Bucket Bundle	
44.....	665301.....	5' Bucket Weldment	1
41.....	640126.....	1/4" Locknut	4
42.....	651703.....	HH Cap Screw; 1/4" x 2"	4
43.....	660808.....	Pivot Pin.....	4
45.....	665580	1 3/4" Lift Cylinder.....	2
46.....	665590.....	1 3/4" Bucket Cylinder	2

WARRANTY

Koyker Manufacturing Company (Koyker) warrants to the original purchaser only that the goods manufactured by Koyker are free from defects in material and workmanship under normal use and service and when properly installed for a period of one (1) year from the date of purchase. Any defective part or component must be returned to the factory at the purchaser's expense for inspection by Koyker. The obligation on Koyker is limited to repairing or replacing at its factory any part or component determined to its satisfaction to be defective. **KOYKER SHALL NOT BE LIABLE FOR INCIDENTAL OR CONSEQUENTIAL DAMAGES.** All transportation charges shall be paid by purchaser. Purchaser must notify Koyker of a claim by registered or certified mail, return receipt requested, within thirty (30) days after discovery or the claim shall be deemed waived.

THIS WARRANTY IS EXPRESSLY IN LIEU OF ALL OTHER WARRANTIES, EXPRESSED OR IMPLIED INCLUDING ANY IMPLIED WARRANTY OF MERCHANTABILITY OR FITNESS FOR A PARTICULAR PURPOSE. No warranty is given by Koyker for parts, components, or trade accessories furnished by Koyker but not manufactured by it. They are covered by the warranty of their manufacturer, if any. No person, firm, or corporation including the selling dealer is authorized to assume for Koyker any other liability in connection with the sale of these goods.

User shall notify KOYKER in writing within 30 days, of any accident or occurrence involving KOYKER products resulting in personal injury of property damage and shall cooperate fully with KOYKER in investigating and determining the cause of such accident or occurrence. In the event that user fails to give such notice to KOYKER and so cooperate, user agrees to indemnify and waive KOYKER harmless from all loss or damage arising from such accident or occurrence.

CYLINDER WARRANTY

All cylinder claims shall be handled by Koyker dealers or distributors. All hydraulic cylinders are thoroughly inspected before shipment from factory. Therefore, no claim can be granted where a cylinder has been damaged or abused (including, but not limited to, bent tubes, dents, nicks, abused threads, attempted alterations, or welding), or unless made to Koyker within one (1) year from sale to original purchaser.

Any defective cylinder reported to Koyker within one (1) year from sale by dealer to original purchaser will be replaced after properly inspected by Koyker. In such case, notify your Koyker Dealer and he will give you proper instructions.

If inspection proves the cylinder is not defective and has been abused or otherwise damaged, any charges will be paid by original purchaser immediately after he has been notified of the result of Koyker's inspection of the cylinder sent in for inspection.

Cylinders requiring factory repair more than one (1) year after sale to original purchaser can be given to dealer for return to Koyker with transportation charges prepaid. Leaks around the shaft seal and internal bypass leaks can be field repaired. Service kits are available for this repair.

HYDRAULIC CYLINDERS

INSPECTION AND MAINTENANCE:

Periodically check all hydraulic system connections to insure a leak-free condition. Also, be certain to maintain proper fluid levels in the tractor hydraulic system as in accordance with the method and frequency recommended in the tractor operator's manual.

Use only hydraulic fluids recommended for your tractor hydraulic system by the manufacturer. Recommended hydraulic fluid for operation of the loader is DTE Light Hydraulic Oil Viscosity 150 SUS at 100 Degrees F (SAE 10W).

Keep hydraulic system clean. Be certain to maintain recommended oil filter service intervals.

All internal surfaces of the hydraulic system on your loader have been factory cleaned, inspected, and plugged with protective caps prior to shipment. Be certain all protective caps are securely in place until hydraulic system assembly is completed.

Care must be taken with your loader cylinders. Nicks, scratches, rust or other shaft damage can cause seal damage resulting in cylinder leakage and poor performance.

IMPORTANT:

Read these service tips before beginning assembly of cylinder gland or piston.

1. Keep seals clean from the time they are removed from package until they are installed.
2. Clean the groove or bore into which the seal is to be fitted before installing the seal.
3. Never touch the seal lip in handling. Always pick up the seal by its outer member.
4. Inspect each seal lip carefully for nicks, scratches, and dirt at time of installation. If dirty, use a soft, clean cloth and carefully wipe off seal. **DO NOT** wipe seal with fingers as this only imbeds dirt in the seal.

NOTE:

Seals can be made more pliable and easier to install, if first heated in hydraulic oil to 160 degrees F. Never use direct heat on any seals.

IMPORTANT:

Never clean rubber related seals with a mineral based solvent! Clean rubber seals in denatured alcohol or non-mineral based solvents only.

1 3/4" CYLINDER SERVICE KITS

KIT NO. 663304:

Complete kit with all seals needed to service one (1) 1 3/4" Cylinder. Consists of:

1 each	1 3/4" Gland "O" Ring
1 each	1 3/4" Backup Ring
1 each	1" EZ Squeeze Rod Seal
1 each	1" Rod Wiper
2 each	1 3/4" EZ Squeeze Piston Seal
1 each	5/8" Rod "O" Ring

KIT NO. 663305:

Complete assembled 1 3/4" Cylinder Gland with all seals. Consists of:

1 each	1 3/4" Aluminum Gland
1 each	1 3/4" Gland "O" Ring
1 each	1 3/4" Backup Ring
1 each	1" EZ Squeeze Rod Seal
1 each	1" Rod Wiper

KIT NO. 663306:

Complete assembled 1 3/4" Cylinder Piston with all seals. Consists of:

1 each	1 3/4" Aluminum Piston
2 each	1 3/4" EZ Squeeze Piston Seal
1 each	5/8" Rod "O" Ring

KIT NO. 663307:

All seals needed to service one (1) 1 3/4" Cylinder Gland. Consists of:

1 each	1 3/4" Gland "O" Ring
1 each	1 3/4" Backup Ring
1 each	1" EZ Squeeze Rod Seal
1 each	1" Rod Wiper

KIT NO. 663308:

All seals needed to service one (1) 1 3/4" Cylinder Piston. Consists of:

2 each	1 3/4" EZ Squeeze Piston Seal
1 each	5/8" Rod "O" Ring

2" CYLINDER SERVICE KITS

KIT NO. 662051:

Complete kit with all seals needed to service one (1) 2" Cylinder. Consists of:

1 each	2" Gland "O" Ring
1 each	2" Backup Ring
1 each	1 1/4" EZ Squeeze Rod Seal
1 each	1 1/4" Rod Wiper
2 each	2" EZ Squeeze Piston Seal
1 each	3/4" Rod "O" Ring

KIT NO. 663310:

Complete assembled 2" Cylinder Gland with all seals. Consists of:

1 each	2" Aluminum Gland
1 each	2" Gland "O" Ring
1 each	2" Backup Ring
1 each	1 1/4" EZ Squeeze Rod Seal
1 each	1 1/4" Rod Wiper

KIT NO. 663311:

Complete assembled 2" Cylinder Piston with all seals. Consists of:

1 each	2" Aluminum Piston
2 each	2" EZ Squeeze Piston Seal
1 each	3/4" Rod "O" Ring

KIT NO. 663312:

All seals needed to service one (1) 2" Cylinder Gland. Consists of:

1 each	2" Gland "O" Ring
1 each	2" Backup Ring
1 each	1 1/4" EZ Squeeze Rod Seal
1 each	1 1/4" Rod Wiper

KIT NO. 663313:

All seals needed to service one (1) 2" Cylinder Piston. Consists of:

2 each	2" EZ Squeeze Piston Seal
1 each	3/4" Rod "O" Ring

HYDRAULIC CYLINDER PARTS LIST

2" CYLINDER PARTS LIST:

LIFT CYLINDER (Part No. 660803):

Key	Part Number	Description	Quantity
1	665343	Tube Weldment	1
2	661076	3/4" Locknut	1
3	651548	Piston Assembly	1
4	661654	1" "O" Ring	1
5	651549	Gland Assembly	1
6	665344	Rod Weldment	1
-	662051	Seal Kit	1

BUCKET CYLINDER (Part No. 660804):

1	665349	Tube Weldment	1
2	661076	3/4" Locknut	1
3	651548	Piston Assembly	1
4	661654	3/4" "O" Ring	1
5	651549	Gland Assembly	1
6	665350	Rod Weldment	1
-	662051	Seal Kit	1

1 3/4" CYLINDER PARTS LIST:

LIFT CYLINDER (Part No. 665580):

1	665582	Tube Weldment	1
2	655022	5/8" Locknut	1
3	655004	Piston Assembly	1
4	655023	5/8" "O" Ring	1
5	655003	Gland Assembly	1
6	665581	Rod Weldment	1
-	663304	Seal Kit	1

BUCKET CYLINDER (Part No. 665590):

1	665592	Tube Weldment	1
2	655022	5/8" Locknut	1
3	655004	Piston Assembly	1
4	655023	5/8" "O" Ring	1
5	655003	Gland Assembly	1
6	665591	Rod Weldment	1
-	663304	Seal Kit	1

HYDRAULIC CYLINDER PARTS DIAGRAM

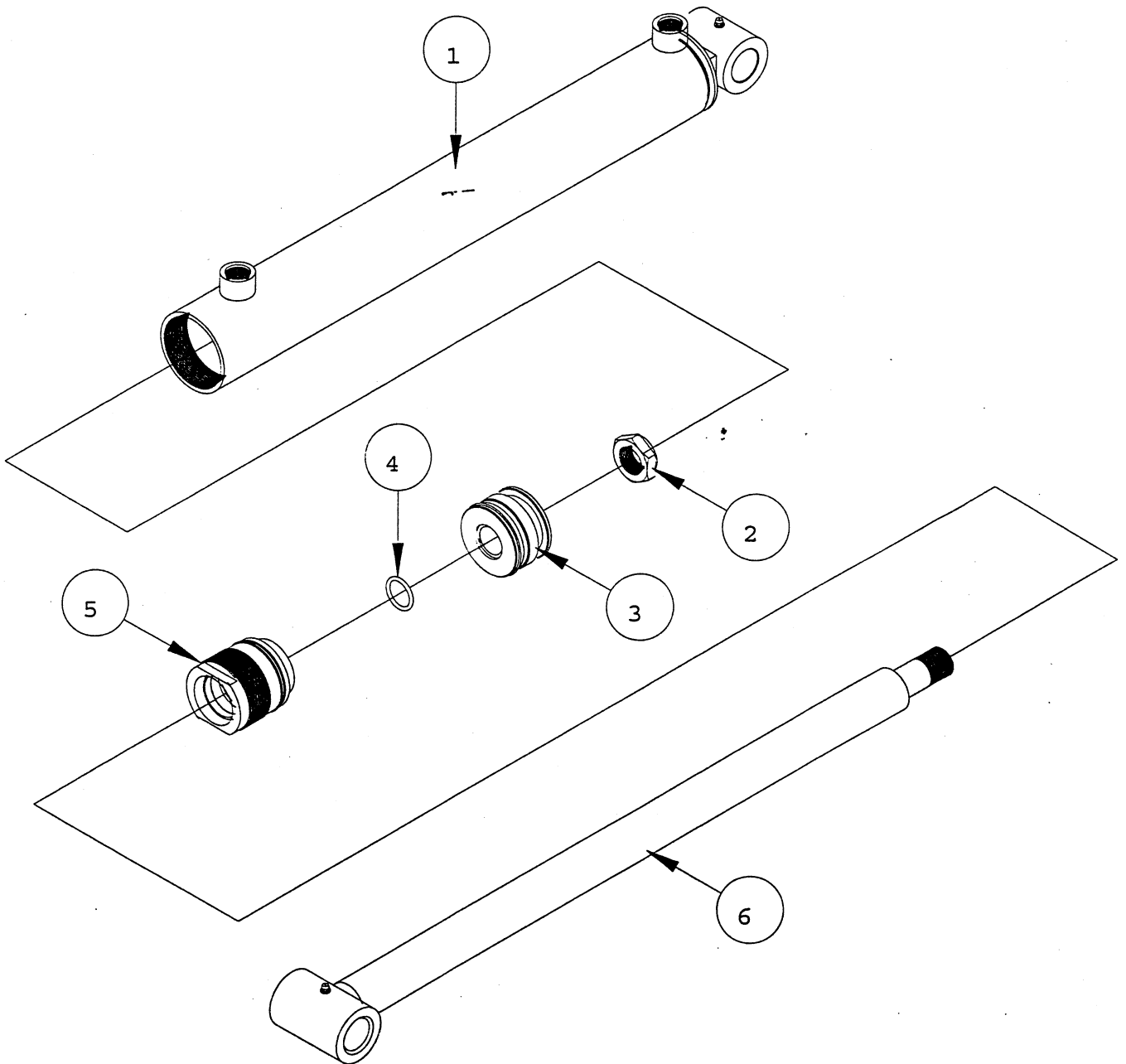

CYLINDER GLAND SERVICE DIAGRAM

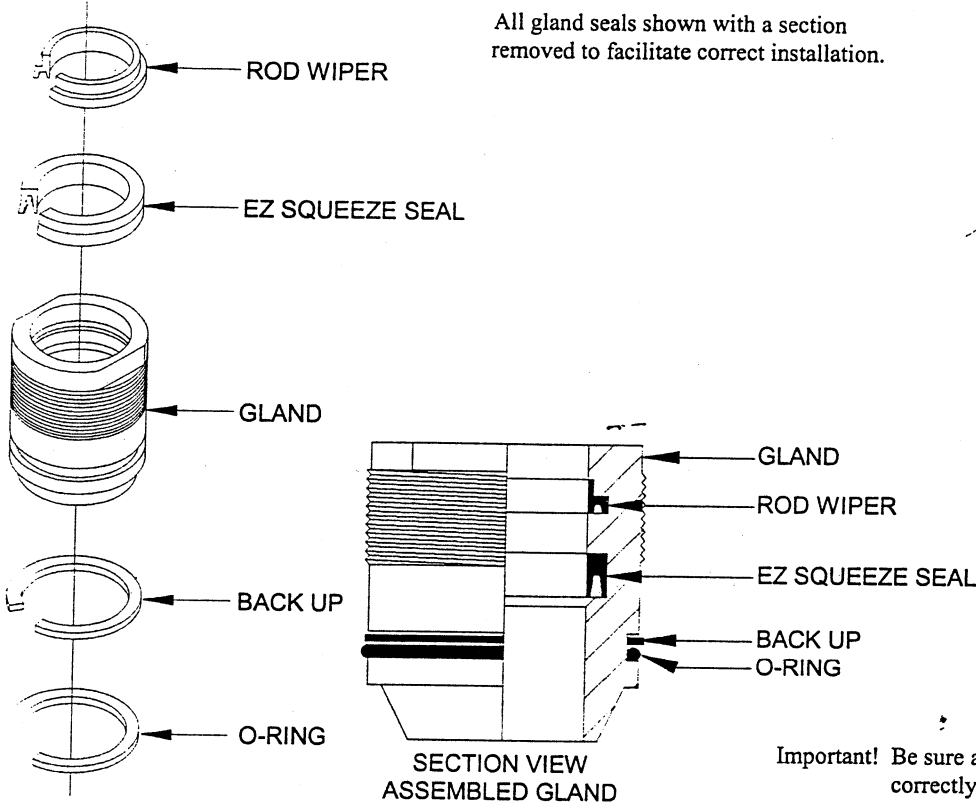

All gland seals shown with a section removed to facilitate correct installation.

Note: To install rod wiper and EZ-squeeze seal, fold similar to shape shown below, slip into gland bore and locate each in its respective groove. Tools are used to fold seals, take care not to damage sealing surfaces.

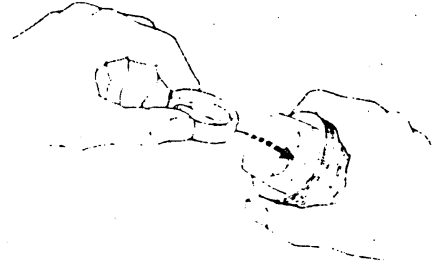

Important! Be sure all gland and piston seals have been installed correctly before cylinder is assembled!

CYLINDER PISTON SERVICE DIAGRAM

To Remove Seals:

Carefully cut across each seal with a sharp knife. Be sure not to scratch sealing surfaces of aluminum piston. If a sharp knife is not available. An electric soldering gun or hot iron may be used to melt throughout seals.

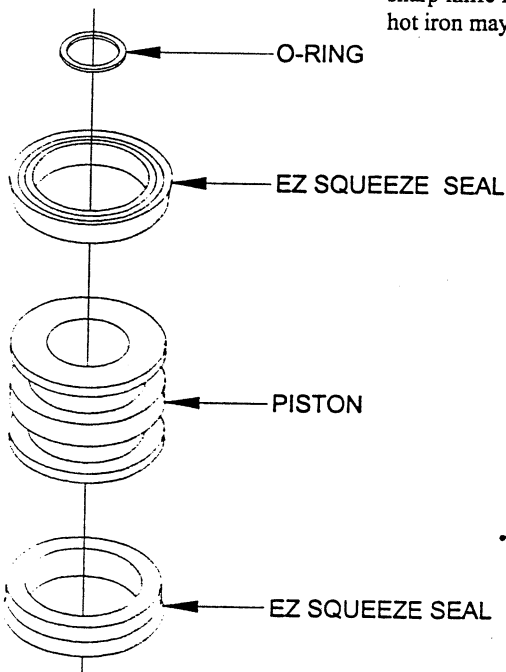

To Install Seals:

1. Thoroughly clean piston sealing surface of all foreign matter.
2. Heat new seals in hydraulic oil to 160° F. Never use a direct flame or heated water on hydraulic seals.
3. Remove seals from oil, wipe dry and install in piston grooves as shown in illustration at left. Be sure seals have completely seated in piston grooves before allowed to cool.
4. Replace piston on cylinder shaft and assemble cylinder when seals have cooled to room temperature.

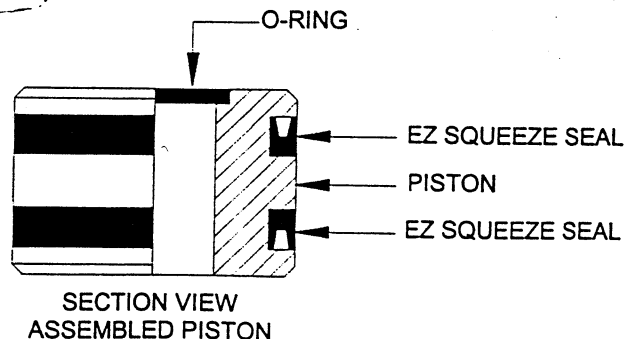
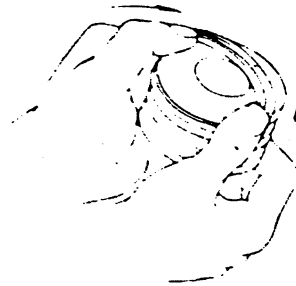

DINOIL VALVE HOOKUP

NOTE: Valve normally shipped open center Part No. #655446 W/Joystick

Open Center

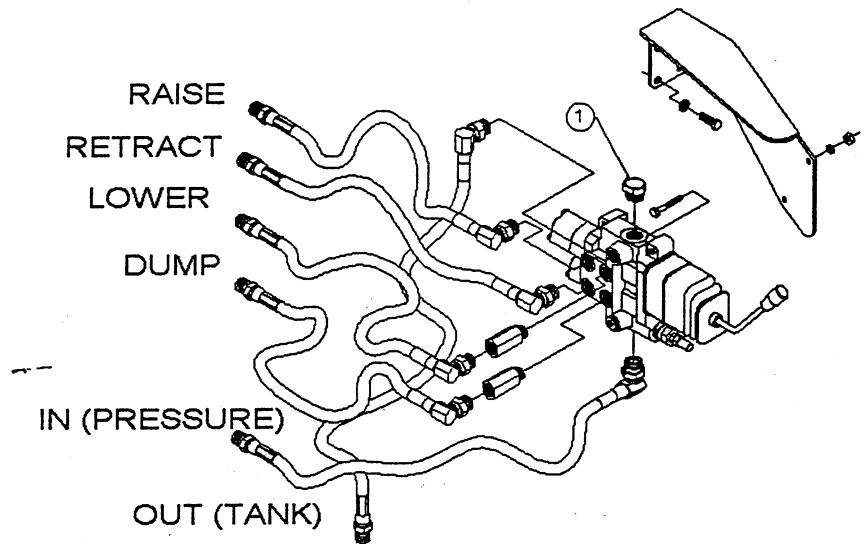

Closed Center

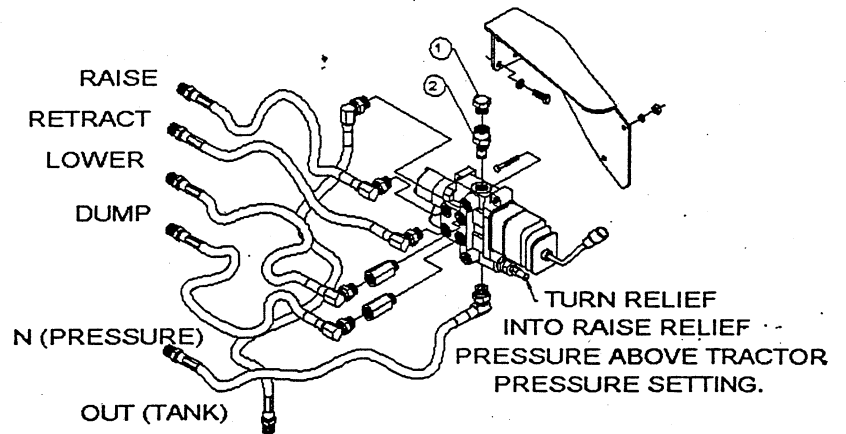

For closed center applications item one (655445) is replaced by item two (655444) and item one is installed in item two.

Power Beyond

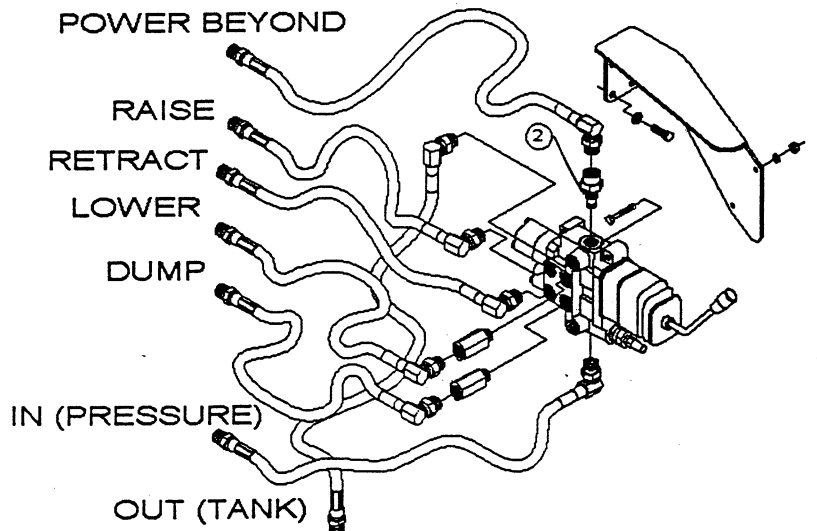

For power beyond applications item one (655445) plug, must be removed and item two (655444) power beyond sleeve must be added.

