

# OWNERS MANUAL

MANUAL NO. 658657

6/13/01

# KOYKER<sup>®</sup>

# 175

# LOADER

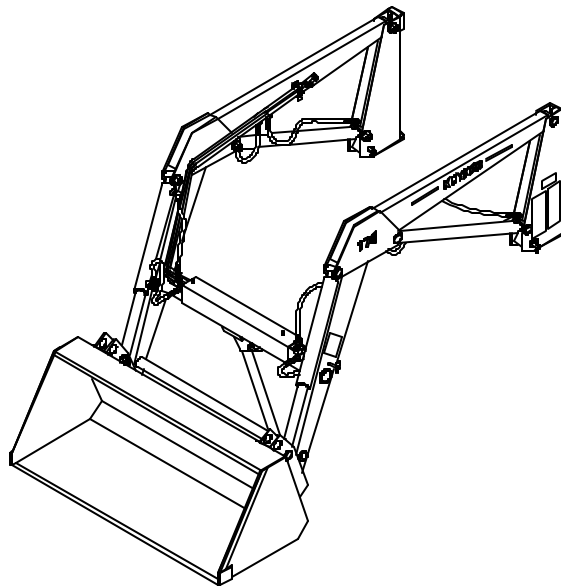

**IMPORTANT-KOYKER DEALER  
BE SURE THIS MANUAL IS GIVEN TO THE  
PURCHASER FOR FUTURE REFERENCE**

**KOYKER MFG. CO., P.O. BOX 409,  
LENNOX, SD 57039**

Phone 1-800-456-1107 E-mail [koyker@koykermfg.com](mailto:koyker@koykermfg.com)

# CONTENTS

<b>CONTENTS</b>	<b>PAGE</b>
Introduction.....	1
<b>SAFETY INFORMATION</b>	
Safety Alert Symbol .....	2
Safety Information .....	3 - 5
Safety Decals .....	6
Tractor & Safety Pointers .....	7
<b>ASSEMBLY INSTRUCTIONS</b>	
Attaching Loader .....	8
Attaching Bucket .....	8
Detaching Loader.....	9
<b>OPERATING INSTRUCTIONS</b>	
Operation.....	10
<b>SERVICE AND MAINTENANCE</b>	
Specifications.....	11
Loader Inspection, Lubrication and Maintenance .....	12
Hydraulic System Parts Schedule .....	13
Hydraulic System Parts Diagram.....	14
“175” Loader Diagram .....	15
Parts Identification Schedule .....	16 - 17
Hydraulic Cylinder Information .....	18
1 3/4” Cylinder Service Kit .....	19
2” Cylinder Service Kit .....	20
Cylinder Parts Schedule.....	21
Cylinder Parts Diagram .....	22
Piston and Gland Diagram .....	23
Dinoil Valve Hookup.....	24
<b>WARRANTY INFORMATION</b>	
Cylinder Warranty .....	25
Warranty .....	26

## INTRODUCTION

For years, Koyker Manufacturing Company of Lennox, South Dakota, has provided the farm loader industry with innovative ideas for a more efficient and dependable means of material handling. Now, with the increasing popularity of the MFWD (Mechanical Front Wheel Drive) tractors, Koyker has again met the challenge and provided the market with a loader that will allow the efficient use of these tractors in material handling. The KOYKER 175 Loader provides you with state-of-the-art design and innovation for your handling chores.

Features such as quality construction, ease of maintenance, and high performance operating capacities, all at a low price, make the new 175 Loader one of the most efficient loaders ever. With proper care and handling, it will provide many years of dependable service.

This manual is designed to provide you with important information regarding the basic loader and bucket. Our sincere intent, in providing this manual, is to help you or those involved better understand the machine and to prevent accidents.

Should you have any questions, comments, improvements, or suggestions regarding the contents of any of the manuals provided, please contact Koyker Manufacturing Company. (800-456-1107 or E-mail [koyker@koykermfg.com](mailto:koyker@koykermfg.com)).

**We care about your safety!**

**Remember ALL safety decals are no charge from the factory. Please replace all safety decals if missing or damaged. Your safety is important to us.**

## SAFETY ALERT SYMBOL

The symbol shown below is used to call your attention to instructions concerning your personal safety. Watch for this symbol it points out important safety precautions. It means **ATTENTION! Become Alert! Your Personal Safety Is Involved!**

Read the message that follows and be alert to the possibility of personal injury or death.

**DANGER:** Indicates an imminently hazardous situation that, if not avoided, will result in death or serious injury.

**WARNING:** Indicates a potentially hazardous situation that, if not avoided, could result in death or serious injury.

**CAUTION:** Indicates a potentially hazardous situation that, if not avoided may result in minor or moderate injury.



### WARNING!

Anyone who will operate or work around a front-end loader should first read this manual.



# SAFETY

Improper use of a loader can cause serious injury or death. The following safety precautions, and those given on the tractor mount installation instructions, should be thoroughly understood before attempting to operate this machine.

## **BEFORE OPERATING:**

Carefully study and understand this manual, the specific tractor mount instructions, and the attachment(s) manual(s).

Prior to operation, inspect the loader for system leaks and damaged, missing, or malfunctioning components in an effort to avoid the possibility of a dangerous failure involving structural members or hydraulic system components.

Be certain any repairs necessary are completed prior to loader operation.

Follow recommended maintenance procedures and precautions on Page 12.

Completely familiarize yourself and others involved with the operation of the hydraulic control valve before operating the loader.

Be certain all bystanders are clear of the machine and operation area prior to operation.

It may be necessary to add wheel ballast or rear weights as recommended by the tractor manufacturer to maintain stability of the machine to prevent tipping or upset which could result in serious injury or death. See mounting instructions for specific information.

It is recommended that both front and rear wheel treads be set to the widest recommended width to prevent tipping or upset which could result in serious injury or death.

This loader is designed for farm type operations such as snow removal, barn and feedlot cleaning or light grading and digging. It's design is **NOT** intended for commercial and/or industrial use.

## **DURING OPERATION:**

Never operate the machine other than from the tractor operator's seat.

Be sure operating area is clear of others during machine operations.

Never lift, hoist, or carry humans in the bucket or on any portion of the loader or loader attachments. Failure to heed, may result in serious injury or death.

## **SAFETY CONTINUED**

Transport the machine load at the slowest speed possible and with the loader boom at the lowest transport position to avoid tipping or upsetting, which may result in serious injury or death.

Be extremely careful when working on inclines or near loose fill, rocks, and holes as they can cause tipping or upsetting which may result in serious injury or death.

Be certain to avoid overhead electrical wires when operating loader. Contact with power lines may cause serious injury or death.

Avoid sudden stops when lowering or lifting the loader boom to prevent loss of control over the machine and/or load, which may result in serious injury or death.

Use maximum ballast and the widest recommended wheel setting on your tractor when handling large shiftable loads.

Never attempt to ram with the bucket at high speed or full tractor power. Sudden impact may result in structural failure and possible serious injury or death.

Never adjust or perform maintenance on the loader or tractor with the unit in motion, or without power source locked out.

Never get under bucket or lift arms or reach through the lift arms or bucket linkage when the loader is in operation. Inadvertent movement may cause serious injury or death.

### **FOLLOWING OPERATION:**

Whenever the machine is not in operation, lower the loader boom and set the tractor brakes, disengage drive, shut the engine off, and remove the ignition key before dismounting the tractor.

If loader is to be disengaged from tractor, be sure the loader is securely supported on a hard, level surface and the stand is securely engaged. Be certain all connections between tractor and loader are free before disengaging.

### **TRANSPORTING:**

Use safety lights and SMV emblem in addition to whatever local codes require when equipment is being transported on the road or highway. Check with proper authorities for legal limitations.

Transport all loads at a slow and safe speed.

Carry the load as low as possible and maintain adequate visibility and good round clearance at all times.

## SAFETY CONTINUED

### PERFORMING MAINTENANCE:

Carefully review, understand, and follow the “maintenance” section in this owners manual before attempting to service loader.

Lower the bucket or attachment to the ground, shut off tractor engine, and relieve pressure in the hydraulic system before adjusting, lubricating, or servicing the loader.

Escaping hydraulic oil under pressure can penetrate the skin. Never use any part of your body to check for hydraulic leaks. Use cardboard when checking for leaks. See Fig. 1-1. Relieve hydraulic pressure before disconnecting any hydraulic line. Failure to heed may result in serious injury or death.

Before disconnecting hydraulic lines, lower the loader and attachments. Lock out the hydraulic supply and relieve all hydraulic pressure.

Replace any damaged or painted-over decals. See Page 7 for replacement decals.

### REMEMBER:

1. Move Slowly!
2. Always use care and common sense!
3. Be careful for your own sake and for that of others!
4. Koyker Mfg. Co. includes all reasonable means for accident prevention except a safe and careful operator.

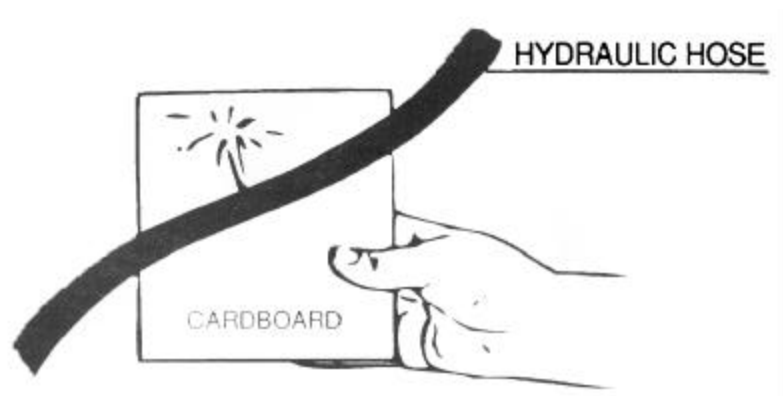



FIG. 1-1

# SAFETY DECALS

	<h2 style="background-color: orange; color: black; padding: 5px;">⚠ WARNING</h2> <p><b>HIGH-PRESSURE FLUID HAZARD</b></p> <p>To prevent serious injury or death:</p> <ul style="list-style-type: none"> <li>• Relieve pressure on hydraulic system before servicing or disconnecting hoses.</li> <li>• Wear proper hand and eye protection when searching for leaks. Use wood or cardboard instead of hands.</li> <li>• Keep all components in good repair.</li> <li>• Refer to owners manual if injury should occur.</li> </ul> <p style="text-align: right; font-size: small;">666943</p>
---	---

<h2 style="background-color: orange; color: black; padding: 5px;">⚠ WARNING</h2>

<p>To avoid injury or death caused by falling loads:</p> <ul style="list-style-type: none"> <li>• Do not handle round bales unless loader is equipped with approved bale handling attachments.</li> <li>• Handle raised loads with caution</li> <li>• Carry load low</li> <li>• Read operators manual</li> </ul>
<h2 style="background-color: orange; color: black; padding: 5px;">⚠ WARNING</h2>

<p>To avoid injury from falls:</p> <ul style="list-style-type: none"> <li>• Do not work from or allow riders on loaders or its attachments</li> </ul> <p><b>KOYKER MFG CO. INCLUDES ALL REASONABLE MEANS FOR ACCIDENT PREVENTION EXCEPT A SAFE AND CAREFUL OPERATOR.</b></p> <p style="text-align: right; font-size: x-small;">666944</p>

<h2 style="background-color: orange; color: black; padding: 5px;">⚠ WARNING</h2>

<p>To avoid injury from falling loader:</p> <ul style="list-style-type: none"> <li>• Do not walk or perform service under a raised loader.</li> <li>• Lower loader to ground when parked.</li> </ul> <p><b>KOYKER MFG CO. INCLUDES ALL REASONABLE MEANS FOR ACCIDENT PREVENTION EXCEPT A SAFE AND CAREFUL OPERATOR.</b></p> <p style="text-align: right; font-size: x-small;">666946</p>

<h2 style="background-color: red; color: white; padding: 5px;">⚠ DANGER</h2>

<p>Serious injury or death can result from rollovers.</p> <ul style="list-style-type: none"> <li>• Use rops and seatbelt at all times.</li> <li>• Add required rear ballast.</li> <li>• Move wheels to widest recommended setting.</li> <li>• Operate tractor at low seeds.</li> <li>• Carry all loads close to ground.</li> </ul>
<h2 style="background-color: red; color: white; padding: 5px;">⚠ DANGER</h2>

<p>Serious injury or death can result from contact with electric lines.</p> <p><b>KOYKER MFG CO. INCLUDES ALL REASONABLE MEANS FOR ACCIDENT PREVENTION EXCEPT A SAFE AND CAREFUL OPERATOR.</b></p> <p style="text-align: right; font-size: x-small;">666945</p>



## **TRACTOR & SAFETY POINTERS**

The use of good judgment and common sense is necessary by the operator in using this loader. The front and rear wheels should be set for the widest wheel tread to assure best stability. Use extra caution when rear wheel weights and tire ballast are added to a loader-equipped tractor. **DO NOT** ram into frozen dirt piles, frozen manure piles, ice, etc., with great momentum where sudden shock loads are encountered. Serious and costly damage may result to both the loader and the tractor.

When scraping or back dragging do not extend the attachment cylinders more than one half of the cylinder's stroke. A limited amount of leveling may be done, when the loader valving is arranged with a float control. This will prevent damage to cylinder rods. Never ride in the bucket.

Before operating the loader, be sure no one is standing near it. Only one person, the operator, should be on the tractor. Remain at the controls and under no circumstances leave the tractor unattended with the bucket in a raised position.

Never lift a person in the bucket or walk under a raised bucket.

Never drive your loader-equipped tractor down a hill that is steeper than 15 degrees. Carry all loads low and use care on side hills.

Always keep unused PTO shaft clutch levers disengaged.

Keep hands, feet, and clothing away from all moving parts.

Hydraulic oil, under pressure, can cause injury. Be sure that all connections are tight and that all pressure is relieved before disconnecting any lines.

Care must be taken with your loader cylinders. Nicks, scratches, rust, or other shaft damage can result in worn packing causing cylinder leakage and subnormal performance.

**MOVE SLOWLY**

**USE COMMON SENSE**

**BE CAREFUL FOR YOUR OWN SAKE AND THAT OF OTHER PEOPLE**

## ATTACHING LOADER



### **IMPORTANT:**

Never attempt loader attachment on grades which are not reasonably level.

1. Check to be sure that the top surface of both mounting shoes are free of bolts, screws or other obstructions.
2. Drive the tractor slowly and carefully in between the loader arms only far enough to permit hook-up of the hydraulic system hoses.
3. Once all hoses have been properly coupled, drive the tractor forward checking to insure that the bottom of each upright clears the mount shoes.
4. To allow the upright base to settle into the mount shoe, tip the bucket down slowly. After the upright contacts the shoe, engage the upright anchor bar into the rear of the shoe by driving the tractor ahead slowly.
5. To secure the loader, install the 661983 - 3/4" diameter pins. Tighten the 3/4" diameter bolt on the front of the upright to draw the upright to the rear of the shoe.
6. After both uprights are secured to the shoes, raise the loader slowly to disengage and store the loader stand.
7. Prior to operation, be certain to review all safety and operation information contained within this manual.

## ATTACHING BUCKET

1. For pin on buckets, assemble pins and retaining bolts as shown in the Parts Diagram of this manual. Make sure all retaining bolts are secure and lubricate necessary points. Inspect pin and bolts periodically for tightness and wear.

## DETACHING LOADER



### **IMPORTANT:**

Never attempt loader detachment on grades which are not reasonably level.

1. Raise loader frame slightly to permit loader stand storage.
2. Lower loader and tip bucket slightly forward to apply pressure to mount connection. **NOTE:** This will prevent the loader from inadvertently rocking forward when the attachment screws are removed.
3. Loosen the 3/4" bolt on the front of both uprights and remove the 661983 - 3/4" diameter locking pin.
4. Carefully, and very slowly, back out far enough to permit separation of the upright anchor. **NOTE:** Should the loader move when tractor is backed up, try rotating the bucket up or down.
5. Before completely backing out, disconnect and store the loader system hydraulic hoses. It is important that the hoses be properly stored to keep the hose couplers as clean as possible.

### **IMPORTANT:**

Never store the detached loader where insufficient soil bearing capacity exists. Good firm clay or firmly packed dirt are sufficient, providing the area is dry. If stability is in question, use blocking under the stand foot to disperse the load. Failure to heed, may allow the loader to settle and prevent attachment at later date.



### **WARNING:**

Re-couple any hydraulic hose together for your particular hydraulic system when necessary to prevent damage to tractor hydraulics. See your particular mount or hydraulic hookup instructions.

## OPERATION



### **WARNING:**

Never allow anyone to operate the loader until they have carefully reviewed and understood this owners manual.

### **FILLING THE BUCKET:**

Approach and enter the pile with the bucket level.

Roll bucket back gradually as the loader moves through the pile.

### **RAISING THE BUCKET:**

### **WARNING:**



Make sure material in bucket cannot spill out onto tractor when loader boom is raised. Keep clear of overhead obstructions such as trees, limbs or power lines when raising the bucket.

Side cutting is the best method of reducing large stockpiles. If the sides of the pile are too high, use the loader to pull them down and reduce the possibility of slides.

### **WARNING:**



**NEVER** attempt to operate the loader with someone near the loader frame or bucket.

# SPECIFICATIONS

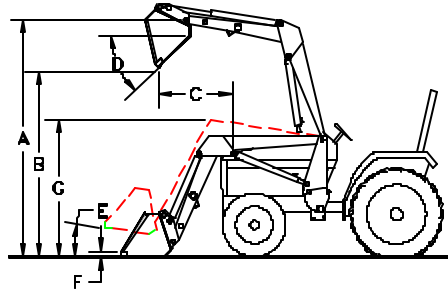

## “175” Loader

Maximum Lift Height (A)	8’ 5”
Clearance W/Bucket Dumped (B)	7’ 11”
Reach at Maximum Height (C)	16”
Maximum Dump Angle (D)	56°
Bucket Rollback (E)	17° **
Digging Depth (F)	5”
Overall Height in Carry Position (G)	4’ 11”

\*Lift Capacity to Full Height at 2300 PSI  
 \*Breakaway Capacity at 2300 PSI  
 Hydraulic Control Valve Requirements

1200 lbs 2” Cylinder; 920 lbs 1 3/4” Cylinder  
 2200 lbs 2” Cylinder; 1650 lbs 1 3/4” Cylinder

Two Spool Selective  
 Control Valve Required for Loader and  
 Hydraulic Controlled Bucket Cylinders

Lift and Bucket Cylinders  
 Bucket Control  
 Standard Bucket  
 Bucket Cylinder Size (Twin)  
 Lift Cylinder Size  
 Approximate Weight W/4 ft. Bucket (Less Mounts)

Double Acting  
 Hydraulic Twin Cylinders

4 ft. & 5 ft. Material  
 2” Bore or 1 3/4” Bore x 19 3/4” Stroke  
 2” Bore or 1 3/4” Bore x 22 3/4” Stroke

597 lbs.

\*Raising Time  
 \*Lower Time  
 \*Bucket Dump Time  
 \*Bucket Rollback Time

6.5 Seconds 2” Cylinder; 5 Seconds 1 3/4” Cylinder  
 5.0 Seconds 2” Cylinder; 3 Seconds 1 3/4” Cylinder  
 5.0 Seconds 2” Cylinder; 4 Seconds 1 3/4” Cylinder  
 4.0 Seconds 2” Cylinder; 3 Seconds 1 3/4” Cylinder

\*Will vary depending upon tractor system capacity.

**\*\*NEVER ATTEMPT FULL ROLLBACK IN RAISED POSITION WITH BUCKET FULL.**



## LOADER INSPECTION, LUBRICATION, AND MAINTENANCE

Lower the bucket to the ground, shut off tractor engine, and relieve the pressure in the hydraulic system before adjusting, lubricating, or servicing the loader.

Inspect all pins and grease fittings before each use and lubricate with heavy duty grease as indicated in this manual.

Periodically check all bolts for looseness and retorque if necessary.

Before storage, be certain all hydraulic cylinders are fully collapsed so that the rod will not be exposed to the elements or damaged.

Be certain hydraulic system remains sealed at all times to prevent contamination.

Check and maintain an adequate fluid level in the tractor reservoir prior to use.

Inspect all hydraulic system hoses and fittings. Replace prior to further operation if damaged.



See Fig. 1.  
to heed may

### WARNING:

Escaping hydraulic oil under pressure can penetrate the skin. Never use any part of your body to check for hydraulic leaks. Use cardboard when checking for leaks. Relieve hydraulic pressure before disconnecting any hydraulic line. Failure result in serious injury or death.

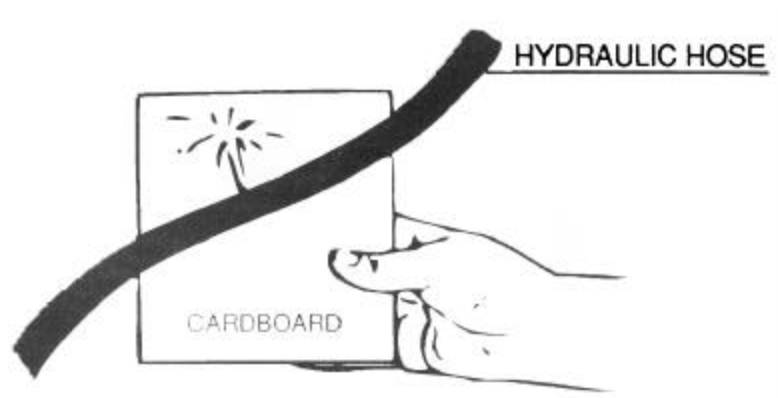

FIG. 1-1

## HYDRAULIC SYSTEM PARTS SCHEDULE

KEY	PART NUMBER	DESCRIPTION	QUANTITY
1.....	659007.....	1st Oil Line (Green) .....	1
2.....	659008.....	2nd Oil Line (Yellow).....	1
3.....	659005.....	3rd Oil Line (Blue).....	1
4 .....	659006.....	4th Oil Line (Red).....	1
5.....	655620.....	2" Lift Cylinder .....	2
6.....	659311 .....	2" Bucket Cylinder.....	2
7.....	655179.....	14" Hydraulic Hose.....	6
8 .....	655180.....	22" Hydraulic Hose.....	2

### OPTIONAL CYLINDERS

9.....	655640.....	1 3/4" Lift Cylinder.....	2
10.....	659308 .....	1 3/4" Bucket Cylinder .....	2

# HYDRAULIC SYSTEM PARTS DIAGRAM

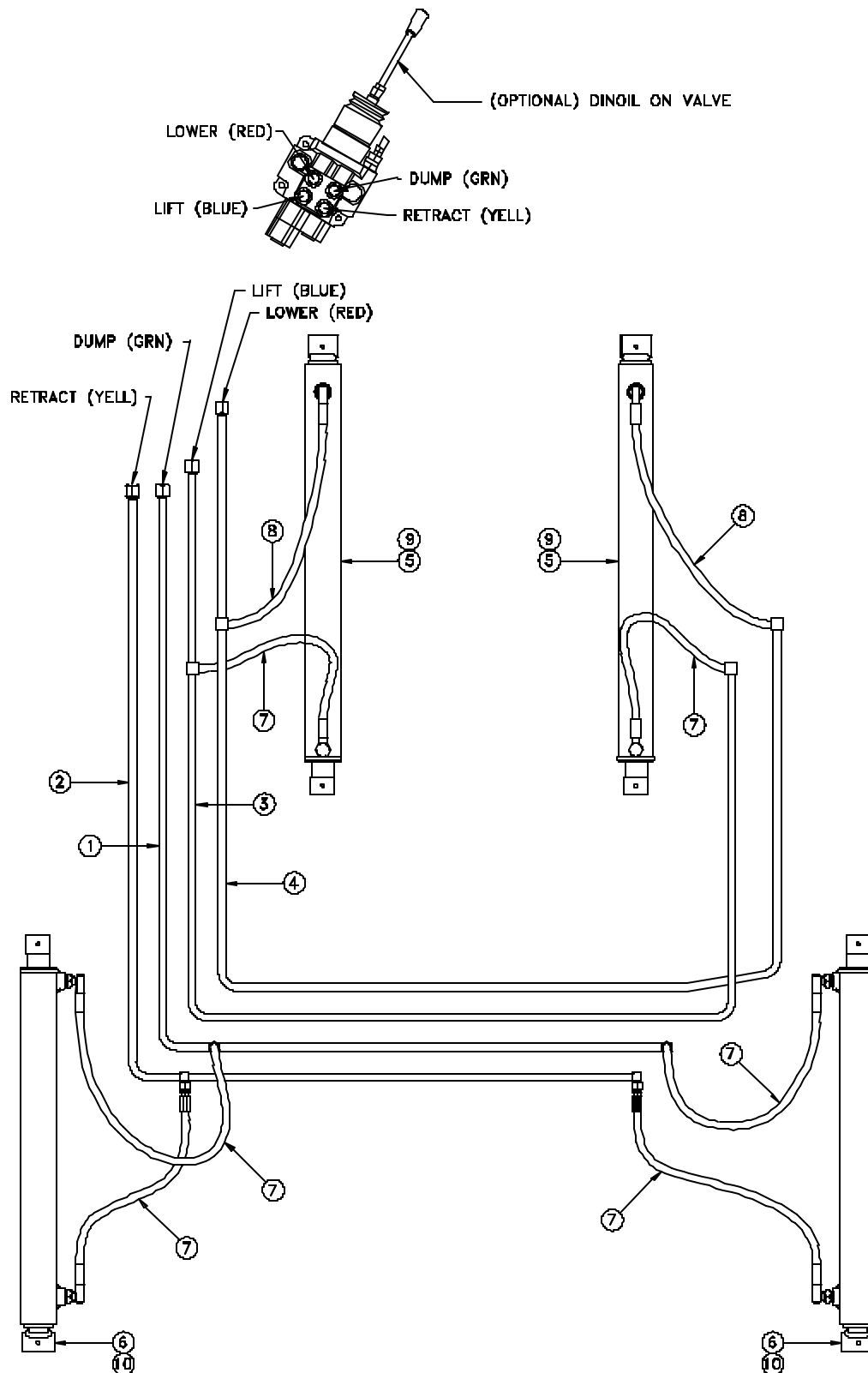



# KOYKER "175" LOADER PARTS DIAGRAM

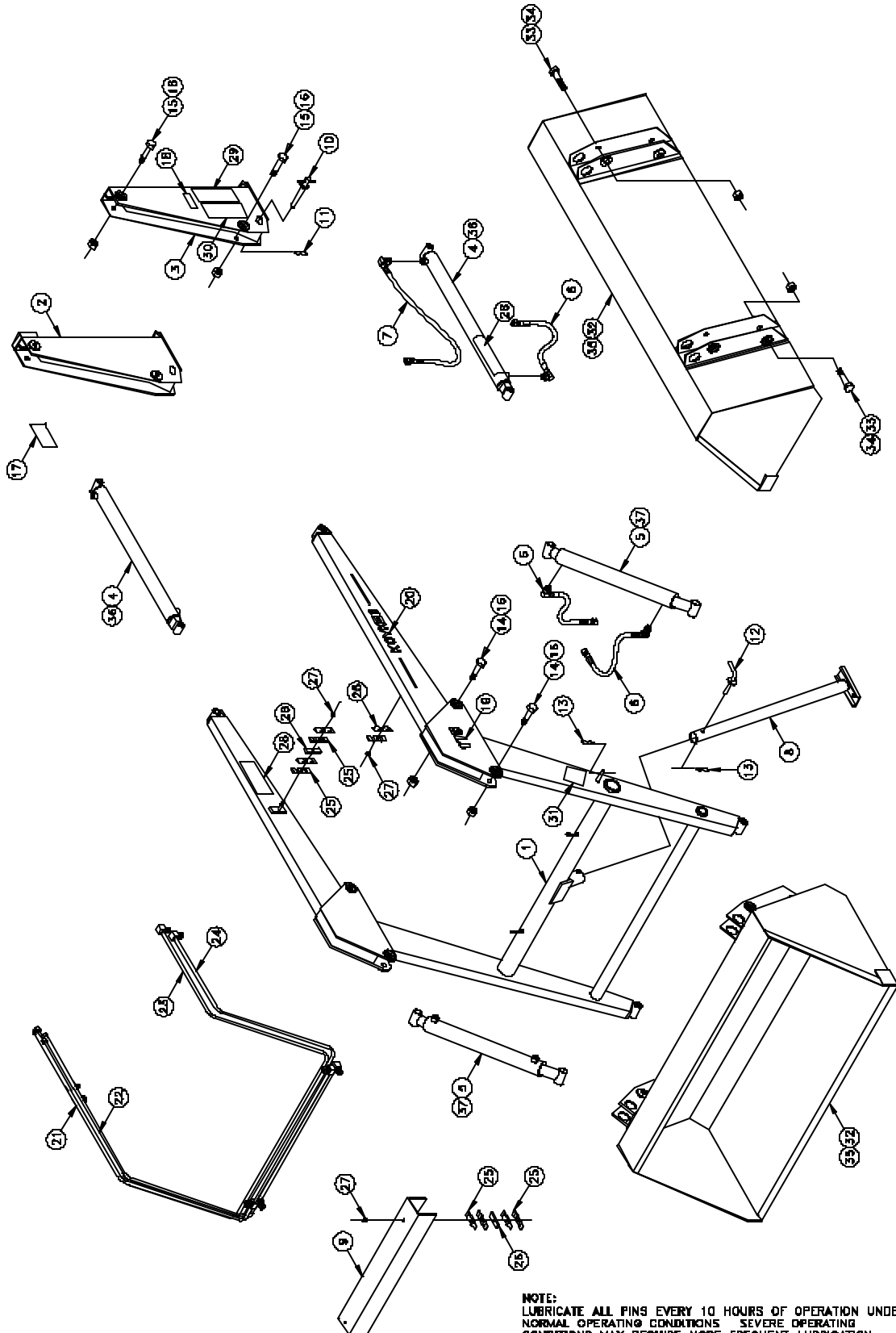

**NOTE:**  
 LUBRICATE ALL PINS EVERY 10 HOURS OF OPERATION UNDER  
 NORMAL OPERATING CONDITIONS SEVERE OPERATING  
 CONDITIONS MAY REQUIRE MORE FREQUENT LUBRICATION

## PARTS IDENTIFICATION SCHEDULE

KEY	PART NUMBER	DESCRIPTION	QUANTITY
1.....	659000.....	Main Frame .....	1
2.....	659001.....	RH Upright .....	1
3.....	659002.....	LH Upright .....	1
4.....	655620.....	2" Lift Cylinder .....	2
5.....	659311 .....	2" Bucket Cylinder .....	2
6.....	655179.....	14" Hydraulic Hose.....	6
7.....	655180.....	22" Hydraulic Hose.....	2
8.....	655635.....	Stand .....	1
9.....	659009.....	Oil Line Cover .....	1
10.....	661983.....	Mount Pin.....	2
11.....	640246.....	#6 Hitch Pin .....	2
12.....	641119.....	Lock Pin .....	1
13.....	640671.....	#3 Hitch Pin .....	2
14.....	640958.....	HH Cap Screw; 3/4" x 3 1/4" .....	4
15.....	640102.....	HH Cap Screw; 3/4" x 3 1/2" .....	4
16.....	640145.....	Jamnut; 3/4" .....	8
17.....	654629.....	"American Made" Decal.....	1
18.....	666941.....	Serial Number Decal.....	1
19.....	659004.....	"175" Decal.....	2
20.....	654632.....	"KOYKER" Decal.....	3
21.....	659007.....	1st Oil Line .....	1
22.....	659008.....	2nd Oil Line .....	1
23.....	659005.....	3rd Oil Line .....	1
24.....	659006.....	4th Oil Line .....	1
25.....	661997.....	Oil Line Clamp .....	14
26.....	661998.....	Oil Line Spacer .....	3
27.....	640128.....	Lock Nut; 5/16" .....	4
28.....	666943.....	Warning Decal .....	5
29.....	666944.....	Warning Decal .....	1
30.....	666945.....	Danger Decal.....	1
31.....	666946.....	Warning Decal .....	2

# PARTS IDENTIFICATION CONTINUED

## Optional Buckets & Cylinders

KEY	PART NUMBER	DESCRIPTION	QUANTITY
	659027	4' Bucket Bundle	
32.....	659026.....	4' Bucket Weldment .....	1
33.....	651216.....	HH Cap Screw; 3/4" x 4".....	4
34.....	640145.....	Jamnut; 3/4" .....	4
	659025	5' Bucket Bundle	
35.....	659024.....	5' Bucket Weldment .....	1
33.....	651216.....	HH Cap Screw; 3/4" x 4".....	4
34.....	640145.....	Jamnut; 3/4" .....	4
36.....	655640 .....	1 3/4" Lift Cylinder.....	2
37 .....	659308 .....	1 3/4" Bucket Cylinder .....	2

# HYDRAULIC CYLINDERS

## INSPECTION AND MAINTENANCE:

Periodically check all hydraulic system connections to insure a leak-free condition. Also, be certain to maintain proper fluid levels in the tractor hydraulic system as in accordance with the method and frequency recommended in the tractor operators manual.

Use only hydraulic fluids recommended for your tractor hydraulic system by the manufacturer. Recommended hydraulic fluid for operation of the loader is DTE Light Hydraulic Oil Viscosity 150 SUS at 100 Degrees F (SAE 10W).

Keep hydraulic system clean. Be certain to maintain recommended oil filter service intervals.

All internal surfaces of the hydraulic system on your loader have been factory cleaned, inspected, and plugged with protective caps prior to shipment. Be certain all protective caps are securely in place until hydraulic system assembly is completed.

Care must be taken with your loader cylinders. Nicks, scratches, rust or other shaft damage can cause seal damage resulting in cylinder leakage and poor performance.

## IMPORTANT:

Read these service tips before beginning assembly of cylinder gland or piston.

1. Keep seals clean from the time they are removed from package until they are installed.
2. Clean the groove or bore into which the seal is to be fitted before installing the seal.
3. Never touch the seal lip in handling. Always pick up the seal by its outer member.
4. Inspect each seal lip carefully for nicks, scratches, and dirt at time of installation. If dirty, use a soft, clean cloth and carefully wipe off seal. **DO NOT** wipe seal with fingers as this only imbeds dirt in the seal.

## NOTE:

Seals can be made more pliable and easier to install, if first heated in hydraulic oil to 160 degrees F. Never use direct heat on any seals.

## IMPORTANT:

Never clean rubber related seals with a mineral based solvent! Clean rubber seals in denatured alcohol or non-mineral based solvents only.

## 1 3/4" CYLINDER SERVICE KITS

### **KIT NO. 663304:**

Complete kit with all seals needed to service one (1) 1 3/4" Cylinder. Consists of:

1 each	1 3/4" Gland "O" Ring
1 each	1 3/4" Backup Ring
1 each	1" U-cup Rod Seal
1 each	1" Rod Wiper
2 each	1 3/4" U-cup Piston Seal
1 each	5/8" Rod "O" Ring

### **KIT NO. 663305:**

Complete assembled 1 3/4" Cylinder Gland with all seals. Consists of:

1 each	1 3/4" Aluminum Gland
1 each	1 3/4" Gland "O" Ring
1 each	1 3/4" Backup Ring
1 each	1" U-cup Rod Seal
1 each	1" Rod Wiper

### **KIT NO. 663306:**

Complete assembled 1 3/4" Cylinder Piston with all seals. Consists of:

1 each	1 3/4" Aluminum Piston
2 each	1 3/4" U-cup Piston Seal
1 each	5/8" Rod "O" Ring

### **KIT NO. 663307:**

All seals needed to service one (1) 1 3/4" Cylinder Gland. Consists of:

1 each	1 3/4" Gland "O" Ring
1 each	1 3/4" Backup Ring
1 each	1" U-cup Rod Seal
1 each	1" Rod Wiper

### **KIT NO. 663308:**

All seals needed to service one (1) 1 3/4" Cylinder Piston. Consists of:

2 each	1 3/4" U-cup Piston Seal
1 each	5/8" Rod "O" Ring

## 2" CYLINDER SERVICE KITS

### **KIT NO. 662051:**

Complete kit with all seals needed to service one (1) 2" Cylinder. Consists of:

1 each	2" Gland "O" Ring
1 each	2" Backup Ring
1 each	1 1/4" U-cup Rod Seal
1 each	1 1/4" Rod Wiper
2 each	2" U-cup Piston Seal
1 each	3/4" Rod "O" Ring

### **KIT NO. 663310:**

Complete assembled 2" Cylinder Gland with all seals. Consists of:

1 each	2" Aluminum Gland
1 each	2" Gland "O" Ring
1 each	2" Backup Ring
1 each	1 1/4" U-cup Rod Seal
1 each	1 1/4" Rod Wiper

### **KIT NO. 663311:**

Complete assembled 2" Cylinder Piston with all seals. Consists of:

1 each	2" Aluminum Piston
2 each	2" U-cup Piston Seal
1 each	3/4" Rod "O" Ring

### **KIT NO. 663312:**

All seals needed to service one (1) 2" Cylinder Gland. Consists of:

1 each	2" Gland "O" Ring
1 each	2" Backup Ring
1 each	1 1/4" U-cup Rod Seal
1 each	1 1/4" Rod Wiper

### **KIT NO. 663313:**

All seals needed to service one (1) 2" Cylinder Piston. Consists of:

2 each	2" U-cup Piston Seal
1 each	3/4" Rod "O" Ring

# HYDRAULIC CYLINDER PARTS SCHEDULE

## 2" CYLINDER PARTS LIST:

### LIFT CYLINDER (Part No. 655620):

KEY	PART NUMBER	DESCRIPTION	QUANTITY
1.....	655621 .....	Tube Weldment .....	1
2.....	661076 .....	3/4" Locknut .....	1
3 .....	651548 .....	Piston Assembly .....	1
4.....	661654 .....	1" "O" Ring .....	1
5.....	651549 .....	Gland Assembly .....	1
6.....	655619 .....	Rod Weldment .....	1
.....	662051 .....	Seal Kit.....	1

### BUCKET CYLINDER (Part No. 659311):

1.....	655629 .....	Tube Weldment .....	1
2.....	661076 .....	3/4" Locknut .....	1
3 .....	651548 .....	Piston Assembly .....	1
4.....	661654 .....	3/4" "O" Ring .....	1
5.....	651549 .....	Gland Assembly .....	1
6.....	655631 .....	Rod Weldment .....	1
.....	662051 .....	Seal Kit.....	1

## 1 3/4" CYLINDER PARTS LIST:

### LIFT CYLINDER (Part No. 655640):

1.....	655642 .....	Tube Weldment .....	1
2.....	655022 .....	5/8" Locknut .....	1
3 .....	655004 .....	Piston Assembly .....	1
4.....	655023 .....	5/8" "O" Ring .....	1
5.....	655003 .....	Gland Assembly .....	1
6.....	655641 .....	Rod Weldment .....	1
.....	663304 .....	Seal Kit.....	1

### BUCKET CYLINDER (Part No. 659308):

1.....	655649 .....	Tube Weldment .....	1
2.....	655022 .....	5/8" Locknut .....	1
3 .....	655004 .....	Piston Assembly .....	1
4.....	655023 .....	5/8" "O" Ring .....	1
5.....	655003 .....	Gland Assembly .....	1
6.....	655652 .....	Rod Weldment .....	1
.....	663304 .....	Seal Kit.....	1

# HYDRAULIC CYLINDER PARTS DIAGRAM

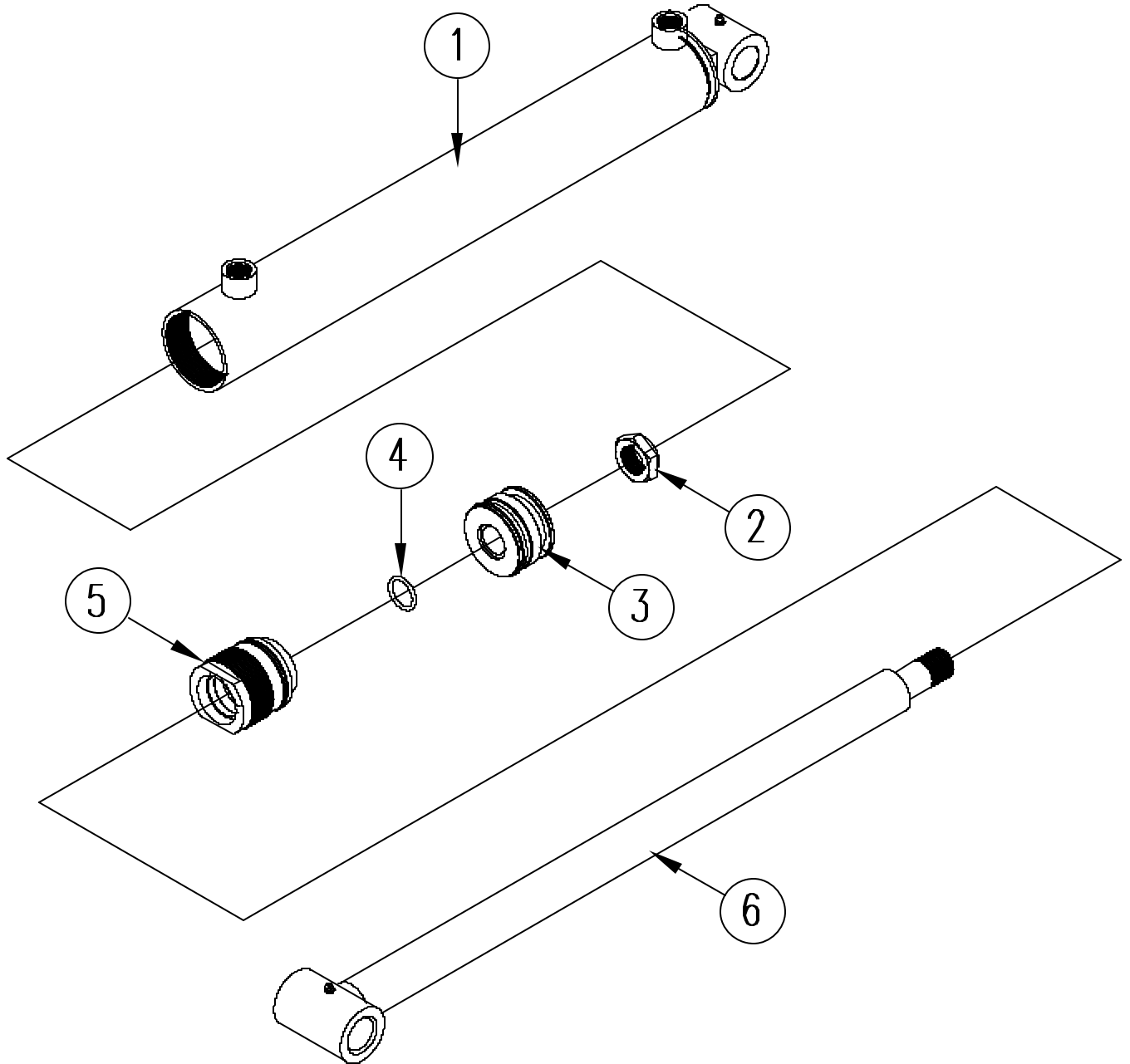



# CYLINDER GLAND SERVICE DIAGRAM

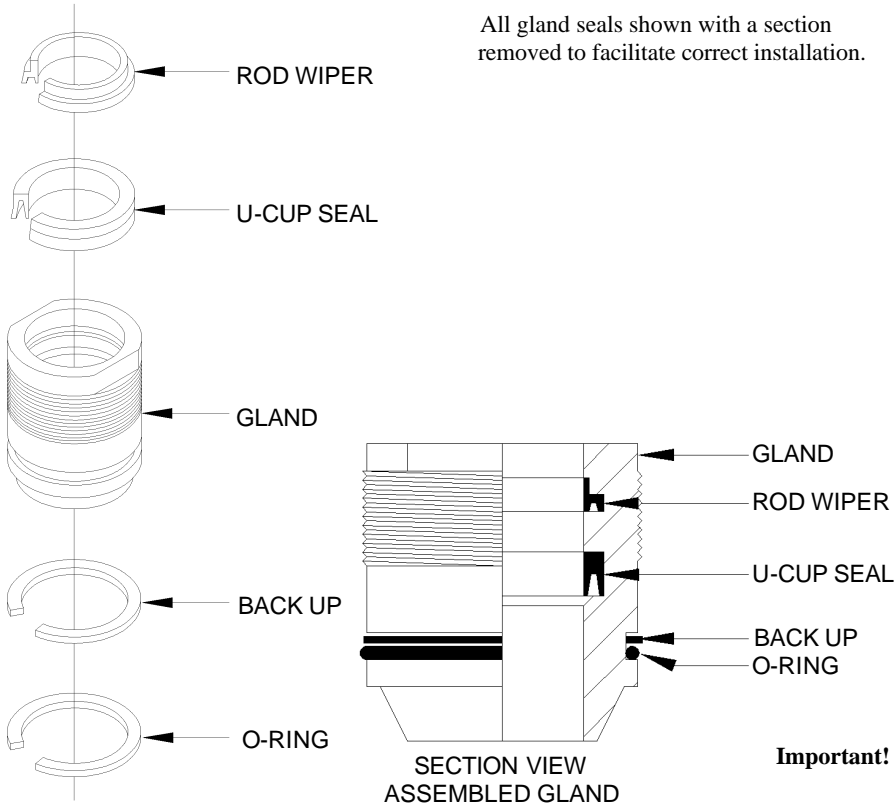

All gland seals shown with a section removed to facilitate correct installation.

Note: To install rod wiper and U-cup seal, fold similar to shape shown below, slip into gland bore and locate each in its respective groove. Tools are used to fold seals, take care not to damage sealing surfaces.



**Important!** Be sure all gland and piston seals have been installed correctly before cylinder is assembled!

# CYLINDER PISTON SERVICE DIAGRAM

## To Remove Seals:

Carefully cut across each seal with a sharp knife. Be sure not to scratch sealing surfaces of aluminum piston. If a sharp knife is not available. An electric soldering gun or hot iron may be used to melt throughout seals.

## To Install Seals:

1. Thoroughly clean piston sealing surface of all foreign matter.
2. Heat new seals in hydraulic oil to 160° F. Never use a direct flame or heated water on hydraulic seals.
3. Remove seals from oil, wipe dry and install in piston grooves as shown in illustration at left. Be sure seals have completely seated in piston grooves before allowed to cool.
4. Replace piston on cylinder shaft and assemble cylinder when seals have cooled to room temperature.

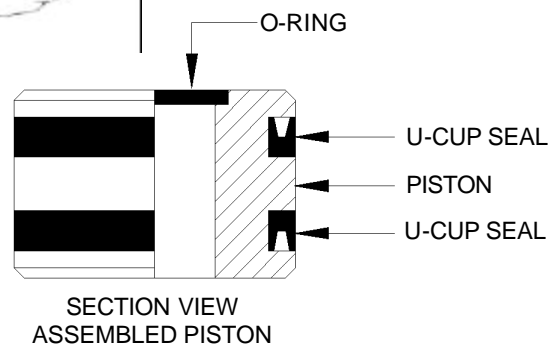
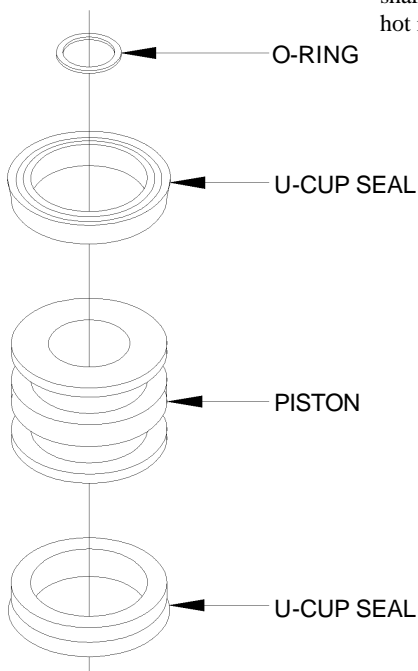

# DINOIL VALVE HOOKUP

NOTE: Valve normally shipped open center Part No. #655446 W/Joystick

Open Center

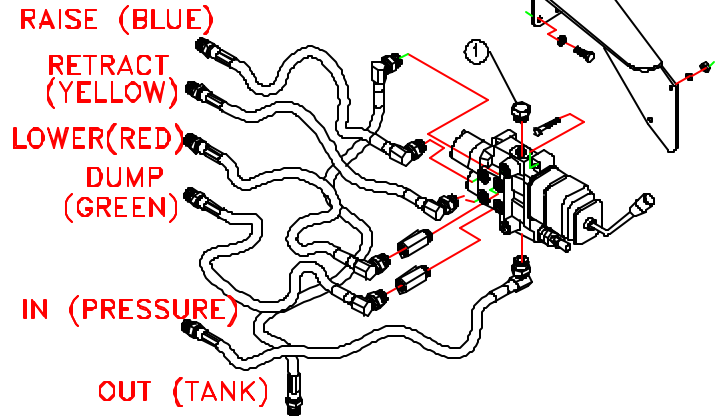

Closed Center

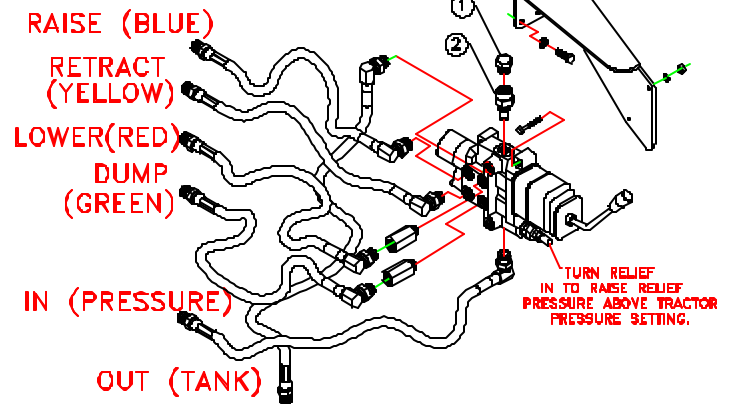

For closed center applications item one (655445) is replaced by item two (655444) and item one is installed in item two.

Power Beyond

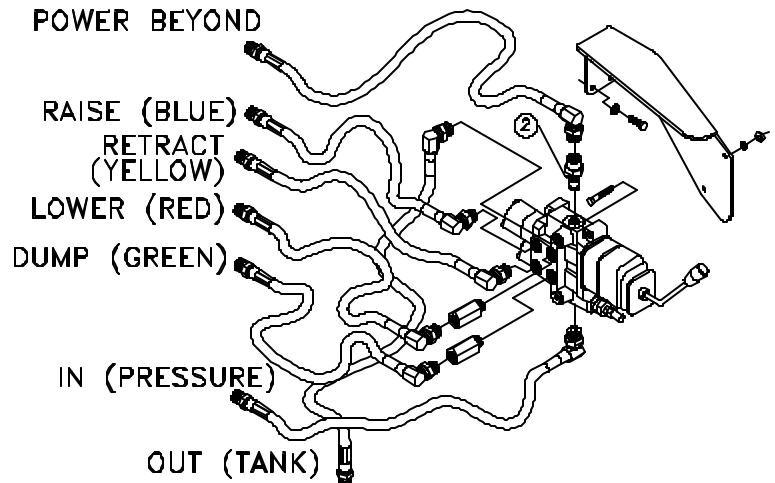

For power beyond applications item one (655445) plug, must be removed and item two (655444) power beyond sleeve must be added.

## **CYLINDER WARRANTY**

All cylinder claims shall be handled by Koyker Dealers or Distributors. All hydraulic cylinders are thoroughly inspected before shipment from factory. Therefore, no claim can be granted where a cylinder has been damaged or abused (including, but not limited to, bent tubes, dents, nicks, abused threads, attempted alterations, or welding), or unless made to Koyker within one (1) year from sale to original purchaser.

Any defective cylinder reported to Koyker within one (1) year from sale by dealer to original purchaser will be replaced after properly inspected by Koyker. In such case, notify your Koyker Dealer and he will give you proper instructions.

If inspection proves the cylinder is not defective and has been abused or otherwise damaged, any charges will be paid by original purchaser immediately after he has been notified of the result of Koyker's inspection of the cylinder sent in for inspection.

Cylinders requiring factory repair more than one (1) year after sale to original purchaser can be given to Dealer for return to Koyker with transportation charges prepaid. Leaks around the shaft seal and internal bypass leaks can be field repaired. Service kits are available for this repair.

All goods being returned to the factory must have a Returned Goods Authorization number (RGA) from Koyker Mfg. (800-456-1107 or E-mail [koyker@koykermfg.com](mailto:koyker@koykermfg.com)). No returned parts will be accepted without an RGA number from Koyker Mfg. RGA number must be written on the box of the returned goods.

## WARRANTY

Koyker Manufacturing Company (Koyker) warrants to the original purchaser only that the goods manufactured by Koyker are free from defects in material and workmanship under normal use and service and when properly installed for a period of one (1) year from the date of purchase. Any defective part or component must be returned to the factory at the purchaser's expense for inspection by Koyker. The obligation on Koyker is limited to repairing or replacing at its factory any part or component determined to its satisfaction to be defective. **KOYKER SHALL NOT BE LIABLE FOR INCIDENTAL OR CONSEQUENTIAL DAMAGES.** All transportation charges shall be paid by purchaser. Purchaser must notify Koyker of a claim by registered or certified mail, return receipt requested, within thirty (30) days after discovery or the claim shall be deemed waived.

**THIS WARRANTY IS EXPRESSLY IN LIEU OF ALL OTHER WARRANTIES, EXPRESSED OR IMPLIED INCLUDING ANY IMPLIED WARRANTY OF MERCHANTABILITY OR FITNESS FOR A PARTICULAR PURPOSE.** No warranty is given by Koyker for parts, components, or trade accessories furnished by Koyker but not manufactured by it. They are covered by the warranty of their manufacturer, if any. No person, firm, or corporation including the selling dealer is authorized to assume for Koyker any other liability in connection with the sale of these goods.

User shall notify KOYKER in writing within 30 days, of any accident or occurrence involving KOYKER products resulting in personal injury of property damage and shall cooperate fully with KOYKER in investigating and determining the cause of such accident or occurrence. In the event that user fails to give such notice to KOYKER and so cooperate, user agrees to indemnify and waive KOYKER harmless from all loss or damage arising from such accident or occurrence.

All goods being returned to the factory must have a Returned Goods Authorization number (RGA) from Koyker Mfg. (800-456-1107 or E-mail [koyker@koykermfg.com](mailto:koyker@koykermfg.com)). No returned parts will be accepted without an RGA number from Koyker Mfg. RGA number must be written on the box of the returned goods.