

OWNERS MANUAL

MANUAL NO. 670009

9/9/2013

KOYKER[®]

80

LOADER

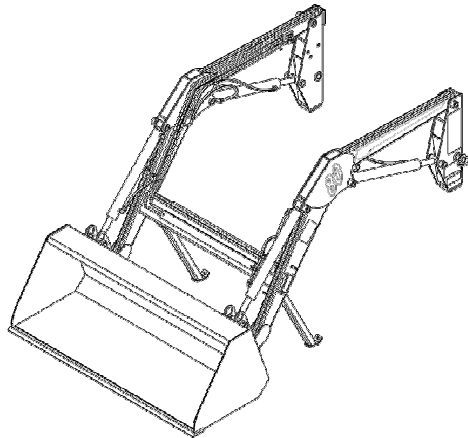

**IMPORTANT-KOYKER DEALER
BE SURE THIS MANUAL IS GIVEN TO THE
PURCHASER FOR FUTURE REFERENCE
KOYKER MANUFACTURING CO., P.O. BOX 409
LENNOX, SD 57039**

Phone 1-800-456-1107 E-mail koyker@koykermfg.com

CONTENTS

CONTENTS	PAGE
Introduction	1
SAFETY INFORMATION	
Safety Alert Symbol.....	2
Safety Information	3 - 5
Safety Decals.....	6
Tractor & Safety Pointers.....	7
ASSEMBLY INSTRUCTIONS	
Attaching Loader.....	8
Attaching Bucket.....	8
Detaching Loader	9
OPERATING INSTRUCTIONS	
Operation.....	10
SERVICE AND MAINTENANCE	
Specifications	11
Loader Inspection, Lubrication and Maintenance.....	12
Hydraulic System Parts Schedule	13
Hydraulic System Parts Diagram	14
“80” Loader Parts Diagram.....	15
Parts Identification Schedule.....	16-17
Hydraulic Cylinders Information	18
1 ½” Cylinder Service Kits	19
Cylinder Parts Schedule	20
Cylinder Parts Diagram.....	21
Piston and Gland Service Diagram	22
Dinoil Valve Hookup	23
LIMITED WARRANTY INFORMATION	
Limited Warranty	24

INTRODUCTION

For years, Koyker Manufacturing Company of Lennox, South Dakota, has provided the farm loader industry with innovative ideas for a more efficient and dependable means of material handling. Now, with the increasing popularity of the MFWD (Mechanical Front Wheel Drive) tractors, Koyker has again met the challenge and provided the market with a loader that will allow the efficient use of these tractors in material handling. The KOYKER 80 Loader provides you with state-of-the-art design and innovation for your on-farm handling chores.

Features such as quality construction, ease of maintenance, and high performance operating capacities, all at a low price, make the new 80 Loader one of the most efficient loaders ever. With proper care and handling, it will provide many years of dependable service.

This manual is designed to provide you with important information regarding the basic loader and bucket. Our sincere intent, in providing this manual, is to help you or those involved better understand the machine and to prevent accidents.

Should you have any questions, comments, improvements, or suggestions regarding the contents of any of the manuals provided, please contact Koyker Manufacturing Company (800-456-1107 or E-mail koyker@koykermfg.com).

We care about your safety!

Remember ALL safety decals are no charge from the factory. Please replace all safety decals if missing or damaged. Your safety is important to us.

SAFETY ALERT SYMBOL

The symbol shown below is used to call your attention to instructions concerning your personal safety. Watch for this symbol it points out important safety precautions. It means **ATTENTION! Become Alert! Your Personal Safety Is Involved!**

Read the message that follows and be alert to the possibility of personal injury or death.

DANGER: Indicates an imminently hazardous situation that, if not avoided, will result in death or serious injury.

WARNING: Indicates a potentially hazardous situation that, if not avoided, could result in death or serious injury.

CAUTION: Indicates a potentially hazardous situation that, if not avoided may result in minor or moderate injury.



WARNING!

Anyone who will operate or work around a front-end loader should first read this manual.

SAFETY

Improper use of a loader can cause serious injury or death. The following safety precautions, and those given on the tractor mount installation instructions, should be thoroughly understood before attempting to operate this machine.

BEFORE OPERATING:

Carefully study and understand this manual, the specific tractor mount instructions, and the attachment(s) manual(s).

Prior to operation, inspect the loader for system leaks and damaged, missing, or malfunctioning components in an effort to avoid the possibility of a dangerous failure involving structural members or hydraulic system components.

Be certain any repairs necessary are completed prior to loader operation.

Follow recommended maintenance procedures and precautions on Page 12.

Completely familiarize yourself and others involved with the operation of the hydraulic control valve before operating the loader.

Be certain all bystanders are clear of the machine and operation area prior to operation.

It may be necessary to add wheel ballast or rear weights as recommended by the tractor manufacturer to maintain stability of the machine to prevent tipping or upset which could result in serious injury or death. See mounting instructions for specific information.

It is recommended that both front and rear wheel treads be set to the widest recommended width to prevent tipping or upset which could result in serious injury or death.

This loader is designed for farm type operations such as snow removal, barn and feedlot cleaning, light commercial or light grading and digging. Its design is **NOT** intended for industrial use.

DURING OPERATION:

Never operate the machine other than from the tractor operator's seat.

Be sure operating area is clear of others during machine operations.

Never lift, hoist, or carry humans in the bucket or on any portion of the loader or loader attachments. Failure to heed, may result in serious injury or death.

SAFETY CONTINUED

Transport the machine load at the slowest speed possible and with the loader boom at the lowest transport position to avoid tipping or upsetting, which may result in serious injury or death.

Be extremely careful when working on inclines or near loose fill, rocks, and holes as they can cause tipping or upsetting which may result in serious injury or death.

Be certain to avoid overhead electrical wires when operating loader. Contact with power lines may cause serious injury or death.

Avoid sudden stops when lowering or lifting the loader boom to prevent loss of control over the machine and/or load, which may result in serious injury or death.

Use maximum ballast and the widest recommended wheel setting on your tractor when handling large shiftable loads.

Never attempt to ram with the bucket at high speed or full tractor power. Sudden impact may result in structural failure and possible serious injury or death.

Never adjust or perform maintenance on the loader or tractor with the unit in motion, or without power source locked out.

Never get under bucket or lift arms or reach through the lift arms or bucket linkage when the loader is in operation. Inadvertent movement may cause serious injury or death.

FOLLOWING OPERATION:

Whenever the machine is not in operation, lower the loader boom and set the tractor brakes, disengage drive, shut the engine off, and remove the ignition key before dismounting the tractor.

If loader is to be disengaged from tractor, be sure the loader is securely supported on a hard, level surface and that the stand is securely engaged. Be certain all connections between tractor and loader are free before disengaging.

TRANSPORTING:

Use safety lights and SMV emblem in addition to whatever local codes require when equipment is being transported on the road or highway. Check with proper authorities for legal limitations.

Transport all loads at a slow and safe speed.

Carry the load as low as possible and maintain adequate visibility and good round clearance at all times.

SAFETY CONTINUED

PERFORMING MAINTENANCE:

Carefully review, understand, and follow the “maintenance” section in this owners manual before attempting to service loader.

Lower the bucket or attachment to the ground, shut off tractor engine, and relieve pressure in the hydraulic system before adjusting, lubricating, or servicing the loader.

Escaping hydraulic oil under pressure can penetrate the skin. Never use any part of your body to check for hydraulic leaks. Use cardboard when checking for leaks. See Fig. 1-1. Relieve hydraulic pressure before disconnecting any hydraulic line. Failure to heed may result in serious injury or death.

Before disconnecting hydraulic lines, lower the loader and attachments. Lock out the hydraulic supply and relieve all hydraulic pressure.

Replace any damaged or painted-over decals. See Page 6 for replacement decals.

REMEMBER:

1. Move Slowly!
2. Always use care and common sense!
3. Be careful for your own sake and for that of others!
4. Koyker Mfg. Co. includes all reasonable means for accident prevention except a safe and careful operator.

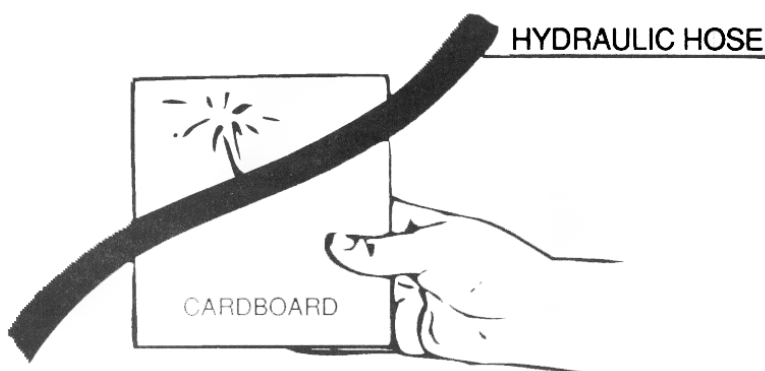
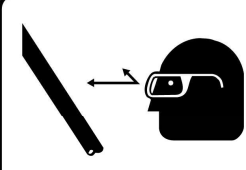



FIG. 1-1

SAFETY DECALS

NOTE: See Parts Diagram of this manual for correct safety decal location.

	<h2 style="margin: 0;">⚠ WARNING</h2>
	<p style="text-align: center;">HIGH-PRESSURE FLUID HAZARD</p> <p>To prevent serious injury or death:</p> <ul style="list-style-type: none"> Relieve pressure on hydraulic system before servicing or disconnecting hoses. Wear proper hand and eye protection when searching for leaks. Use wood or cardboard instead of hands. Keep all components in good repair. Refer to owners manual if injury should occur. <p style="text-align: right; font-size: small;">666943</p>

⚠ WARNING

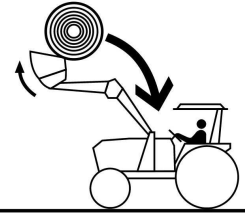

To avoid injury or death caused by falling loads:

- Do not handle round bales unless loader is equipped with approved bale handling attachments.
- Handle raised loads with caution
- Carry load low
- Read operators manual

⚠ WARNING



To avoid injury from falls:

- Do not work from or allow riders on loaders or its attachments

KOYKER MFG CO. INCLUDES ALL REASONABLE MEANS FOR ACCIDENT PREVENTION EXCEPT A SAFE AND CAREFUL OPERATOR.

666944

⚠ WARNING



To avoid injury from falling loader:

- Do not walk or perform service under a raised loader.
- Lower loader to ground when parked.

KOYKER MFG CO. INCLUDES ALL REASONABLE MEANS FOR ACCIDENT PREVENTION EXCEPT A SAFE AND CAREFUL OPERATOR.

666946

⚠ DANGER

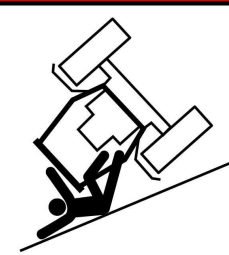

Serious injury or death can result from rollovers.

- Use rops and seatbelt at all times.
- Add required rear ballast.
- Move wheels to widest recommended setting.
- Operate tractor at low seeds.
- Carry all loads close to ground.

⚠ DANGER



Serious injury or death can result from contact with electric lines.

KOYKER MFG CO. INCLUDES ALL REASONABLE MEANS FOR ACCIDENT PREVENTION EXCEPT A SAFE AND CAREFUL OPERATOR.

666945

TRACTOR & SAFETY POINTERS

The use of good judgment and common sense is necessary by the operator in using this loader. The front and rear wheels should be set for the widest wheel tread to assure best stability. Use extra caution when rear wheel weights and tire ballast are added to a loader-equipped tractor. **DO NOT** ram into frozen dirt piles, frozen manure piles, ice, etc., with great momentum where sudden shock loads are encountered. Serious and costly damage may result to both the loader and the tractor.

When scraping or back dragging do not extend the attachment cylinders more than one half of the cylinder's stroke. A limited amount of leveling may be done, when the loader valving is arranged with a float control. This will prevent damage to cylinder rods. Never ride in the bucket.

Before operating the loader, be sure no one is standing near it. Only one person, the operator, should be on the tractor. Remain at the controls and under no circumstances leave the tractor unattended with the bucket in a raised position.

Never lift a person in the bucket or walk under a raised bucket.

Never drive your loader-equipped tractor down a hill that is steeper than 15 degrees. Carry all loads low and use care on side hills.

Always keep unused PTO shaft clutch levers disengaged.

Keep hands, feet, and clothing away from all moving parts.

Hydraulic oil, under pressure, can cause injury. Be sure that all connections are tight and that all pressure is relieved before disconnecting any lines.

Care must be taken with your loader cylinders. Nicks, scratches, rust, or other shaft damage can result in worn packing causing cylinder leakage and subnormal performance.

MOVE SLOWLY

USE COMMON SENSE

BE CAREFUL FOR YOUR OWN SAKE AND THAT OF OTHER PEOPLE

ATTACHING THE LOADER



IMPORTANT:

Never attempt to attach the loader on steep grades, or surfaces which are not reasonably level.

NOTE: Refer to loader mount instruction sheets (provided with mount) for correct and safe mounting of specific loader applications. Refer to hydraulic installation instructions provided with the loader mount kit for specific applications or contact dealer for correct and safe hydraulic hookup.

1. Check to be sure that the top surface of both mounting shoes are free of any obstructions and the loader mount pins are removed.
2. Drive the tractor slowly and carefully in between the loader arms only far enough to permit hook-up of the hydraulic system hoses.
3. Once all hoses have been properly coupled, drive the tractor forward checking to insure that the bottom of each upright clears the mount shoes. It may be necessary to operate the **lift** cylinder control valve either up or down to provide alignment for attachment of the yoke adapter or brace arms.
4. To allow the upright base to settle into the mount shoe, tip the bucket down slowly. After the upright contacts the shoe, be sure that both pilot pins on the bottom of the loader uprights, slide down into the holes in loader mount.
5. Using the loader hydraulics to line up the top holes in the loader mount with the loader upright holes. Secure the loader by installing one mount pin (665421) and one #6 hitch pin (640246) on each side of the loader.
6. After both uprights are secured to the shoes, raise the loader slowly to disengage and store the loader stand.
7. Prior to operation, be certain to review all safety and operation information contained within this manual.

ATTACHING THE BUCKET

1. For pin on buckets, assemble pins and retaining bolts as shown in the Parts Diagram of this manual. Make sure all retaining bolts are secure and lubricate necessary points. Inspect pin and bolts periodically for tightness and wear.

DETACHING THE LOADER



IMPORTANT:

Never attempt to detach the loader on steep grades, or surfaces which are not reasonably level.

1. Remove the loader stands from the cross tube storage location. Raise loader off the ground slightly to allow for the loader stands to be installed. Remember to use the pins and hitch pins to secure the loader stands in position.
2. Lower loader and tip bucket slightly forward to relieve the pressure from the mount connection pins. Remember to shut off tractor and set parking brake before getting off.
3. Remove the #6 hitch pins (640246) and remove the mount pins (665421). If pins do not remove easily, you may need to put the valve in the float position to relieve the pressure.
4. If a front yoke brace is present, remove the hitch pins and lock pins from the front of the yoke or remove the front bolts in each brace pipe.
5. Make sure there is slack in the valve hydraulic lines and all other obstructions are removed. Get on the tractor and start it. Carefully, and very slowly, retract bucket back so pilot pins disengage out of mount holes. Then carefully back out far enough to permit separation of the uprights from the mount pockets.
NOTE: Should the loader move when tractor is backed up, try rotating the bucket up or down to stabilize the loader.
6. Before completely backing out, set the parking brake, shut off the tractor, disconnect and store the loader system hydraulic hoses. It is important that the hoses be properly stored to keep the hose couplers as clean as possible. Remember to Re-couple any tractor hydraulic lines, if necessary.

IMPORTANT:

Never store the detached loader where insufficient soil bearing capacity exists. Good firm clay or firmly packed dirt are sufficient, providing the area is dry. If stability is in question, use blocking under the stand foot to disperse the load. Failure to heed, may allow the loader to settle and prevent attachment at later date.



WARNING: Re-couple any hydraulic hose together for your particular hydraulic system when necessary to prevent damage to tractor hydraulics. See your particular mount or hydraulic hook-up instructions.

OPERATION



WARNING:

Never allow anyone to operate the loader until they have carefully reviewed and understood this owners manual.

FILLING THE BUCKET:

Approach and enter the pile with the bucket level.

Roll bucket back gradually as the loader moves through the pile.

RAISING THE BUCKET:



WARNING:

Make sure material in bucket cannot spill out on to tractor when loader boom is raised. Keep clear of overhead obstructions such as trees, limbs or power lines when raising the bucket.

Side cutting is the best method of reducing large stockpiles. If the sides of the pile are too high, use the loader to pull them down and reduce the possibility of slides.



WARNING:

NEVER attempt to operate the loader with someone near the loader frame or bucket.

SPECIFICATIONS

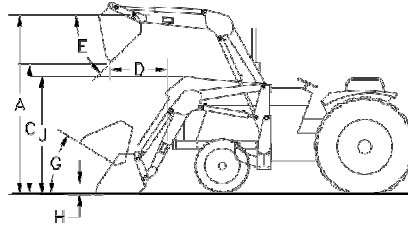

“80” Loader

Maximum lift height to pivot pin (A):	72”
Clearance with bucket dumped (C)	52”
Reach at maximum lift height (D):	24”
Maximum dump angle (E):	45°
**Maximum rollback angle (G):	21°
Digging depth (H):	4”
Overall height in carry position (J):	47”
*Lift capacity to maximum height (V):	500 lbs
*Breakout force (Z):	900 lbs

Hydraulic Control Valve Requirements

Two Spool Selective
Control Valve Required for Loader and
Hydraulic Controlled Bucket Cylinders.

Lift and Bucket Cylinders-	Double Acting
Bucket Control-	Hydraulic Twin Cylinders
Standard Bucket-	3’6” ft. Material
Bucket Cylinder Size (Twin)-	1½” Bore x 14¼” Stroke
Lift Cylinder Size-	1½” Bore x 13 ¹¹ / ₁₆ ”
Stroke	
Approximate Weight w/3’6”ft. Bucket (Less Mounts)-	110 lbs
*Raising Time-	6.0 Seconds 1½” Cylinder
*Lower Time-	3.0 Seconds 1½” Cylinder
*Bucket Dump Time-	3.0 Seconds 1½” Cylinder
*Bucket Rollback Time-	4.0 Seconds 1½” Cylinder

***Will vary depending upon each tractors hydraulic operating pressure, flow rate, RPM’s and oil temperatures. The above data is based on an operating pressure of 2100 PSI, flow of 2.1 gal/min at 1500 RPM’s and room temperature of 60° F.**



****Never attempt maximum rollback at maximum height with material in the bucket. Material may shift causing the tractor to be unstable or may roll out of the bucket causing injury or death.**

Specifications are subject to change without notice and without liability therefore.

LOADER INSPECTION, LUBRICATION, AND MAINTENANCE

Lower the bucket to the ground, shut off tractor engine, and relieve the pressure in the hydraulic system before adjusting, lubricating, or servicing the loader.

Inspect all pins and grease fittings before each use and lubricate with heavy duty grease as indicated in this manual.

Periodically check all bolts for looseness and re-torque if necessary.

Before storage, be certain all hydraulic cylinders are fully collapsed so that the rod will not be exposed to the elements or damaged.

Be certain hydraulic system remains sealed at all times to prevent contamination.

Check and maintain an adequate fluid level in the tractor reservoir prior to use.

Inspect all hydraulic system hoses and fittings. Replace prior to further operation if damaged.



WARNING:

Escaping hydraulic oil under pressure can penetrate the skin. Never use any part of your body to check for hydraulic leaks. Use cardboard when checking for leaks. See Fig. 1-1. Relieve hydraulic pressure before disconnecting any hydraulic line. Failure to heed may result in serious injury or death.

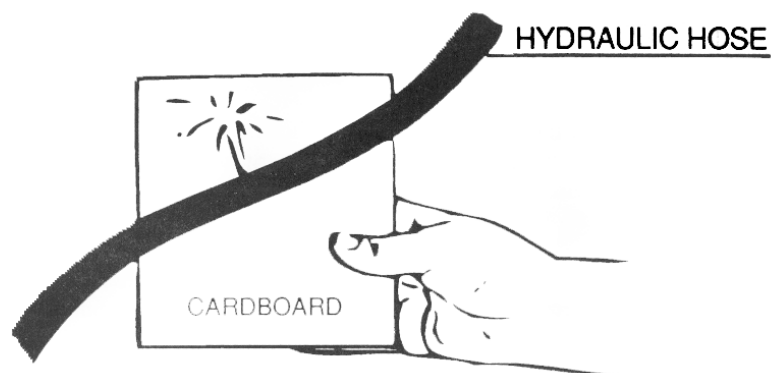
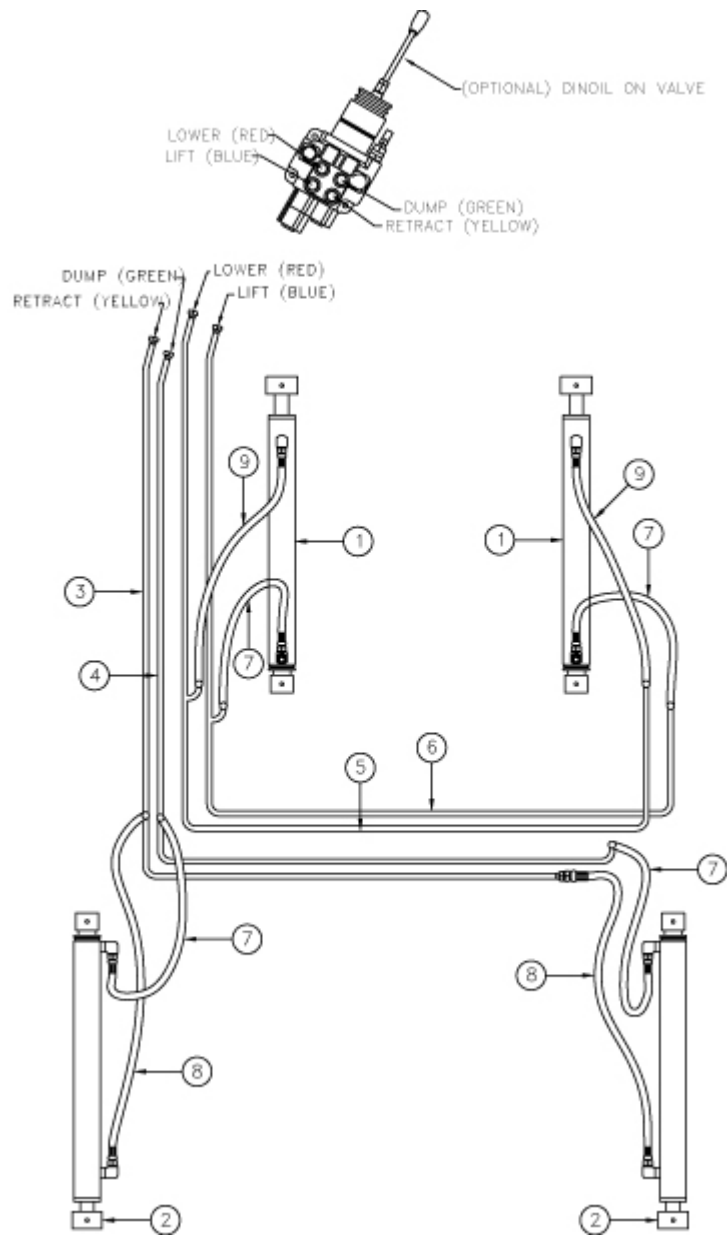

FIG 1-1

HYDRAULIC SYSTEM PARTS SCHEDULE

KEY	PART NUMBER	DESCRIPTION	QUANTITY
1.....	670003.....	1 ½” Lift Cylinder	2
2.....	670004.....	1 ½” Bucket Cylinder.....	2
3.....	670011.....	1st Oil Line (Yellow)	1
4.....	670012.....	2nd Oil Line (Green)	1
5.....	670013.....	3rd Oil Line (Red)	1
6.....	670014.....	4th Oil Line (Blue)	1
7.....	670015.....	12” Hydraulic Hose.....	4
8.....	670016.....	21” Hydraulic Hose.....	2
9.....	670017.....	27” Hydraulic Hose.....	2

HYDRAULIC SYSTEM PARTS DIAGRAM



KOYKER "80" LOADER PARTS DIAGRAM

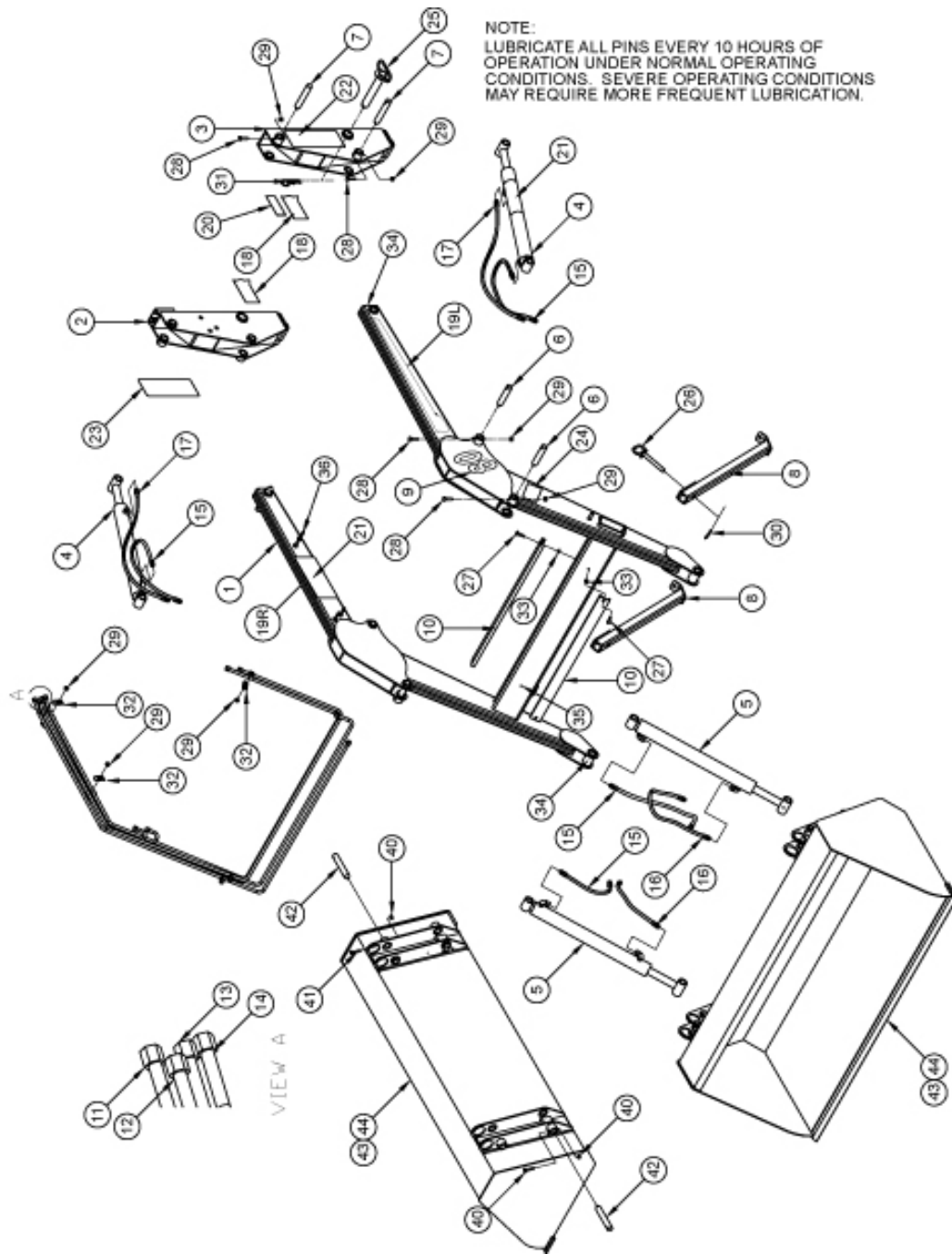

PARTS IDENTIFICATION SCHEDULE

KEY	PART NUMBER	DESCRIPTION	QUANTITY
1	670000	Main Frame	1
2	670001	RH Upright	1
3	670002	LH Upright	1
4	670003	1½" Lift Cylinder	2
5	670004	1½" Bucket Cylinder	2
6	670005	Pivot Pin; 3¾"	4
7	670006	Pivot Pin; 4½"	4
8	670007	Stand	2
9		"80" Decal	2
10	670010	Oil Line Cover	2
11	670011	1st Oil Line	1
12	670012	2nd Oil Line	1
13	670013	3rd Oil Line	1
14	670014	4th Oil Line	1
15	670015	12" Hydraulic Hose	4
16	670016	21" Hydraulic Hose	2
17	670017	27" Hydraulic Hose	2
18	654629	"American Made" Decal	2
19		"Koyker" Decal	2
20	666941	Serial Number Decal	1
21	666943	Warning Decal	5
22	666944	Warning Decal	1
23	666945	Danger Decal	1
24	666946	Warning Decal	2
25	665421	Mount Pin	2
26	641119	Pin	2
27	666031	Self Tapping Screw; 1/4"x 1"	4
28	640009	HH Cap Screw; 1/4" x 1 ½"	8
29	640126	Locknut; 1/4"	13
30	640671	#3 Hitch Pin	4
31	640246	#6 Hitch Pin	2
32	653713	Oil Line Clamp	5
33	670379	Stud Grommet	4

PARTS IDENTIFICATION CONTINUED

Optional Buckets & Cylinders

KEY	PART NUMBER	DESCRIPTION	QUANTITY
	669988	3½' Bucket Bundle	1
40.....	640126.....	Locknut; ¼".....	4
41.....	640009.....	HH Cap Screw; ¼" x 1 ½".....	4
42.....	670006.....	Pivot Pin.....	4
43.....	670018.....	3½' Bucket Weldment.....	1
	669995	4' Bucket Bundle	1
40.....	640126.....	Locknut; ¼".....	4
41.....	640009.....	HH Cap Screw; ¼" x 1 ½".....	4
42.....	670006.....	Pivot Pin.....	4
44.....	670019.....	4' Bucket Weldment.....	1

HYDRAULIC CYLINDERS

INSPECTION AND MAINTENANCE:

Periodically check all hydraulic system connections to insure a leak-free condition. Also, be certain to maintain proper fluid levels in the tractor hydraulic system as in accordance with the method and frequency recommended in the tractor operator's manual.

Use only hydraulic fluids recommended for your tractor hydraulic system by the manufacturer. Recommended hydraulic fluid for operation of the loader is DTE Light Hydraulic Oil Viscosity 150 SUS at 100 degrees F (SAE 10W).

Keep hydraulic system clean. Be certain to maintain recommended oil filter service intervals.

All internal surfaces of the hydraulic system on your loader have been factory cleaned, inspected, and plugged with protective caps prior to shipment. Be certain all protective caps are securely in place until hydraulic system assembly is completed.

Care must be taken with your loader cylinders. Nicks, scratches, rust or other shaft damage can cause seal damage resulting in cylinder leakage and poor performance.

IMPORTANT:

Read these service tips before beginning assembly of cylinder gland or piston.

1. Keep seals clean from the time they are removed from package until they are installed.
2. Clean the groove or bore into which the seal is to be fitted before installing the seal.
3. Never touch the seal lip in handling. Always pick up the seal by its outer member.
4. Inspect each seal lip carefully for nicks, scratches, and dirt at time of installation. If dirty, use a soft, clean cloth and carefully wipe off seal. **DO NOT** wipe seal with fingers as this only imbeds dirt in the seal.

NOTE:

Seals can be made more pliable and easier to install, if first heated in hydraulic oil to 160 degrees F. Never use direct heat on any seals.

IMPORTANT:

Never clean rubber related seals with a mineral based solvent! Clean rubber seals in denatured alcohol or non-mineral based solvents only.

1 1/2" CYLINDER SERVICE KITS

KIT NO. 670084:

Complete kit with all seals needed to service one (1) 1 1/2" Cylinder. Consists of:

1 each	1 1/2" Gland "O" Ring
1 each	1 1/2" Backup Ring
1 each	1" Rod Seal
1 each	1" Rod Wiper
2 each	1 1/2" Piston Seal
1 each	5/8" Rod "O" Ring

KIT NO. 670085:

Complete assembled 1 1/2" Cylinder Gland with all seals. Consists of:

1 each	1 1/2" Aluminum Gland
1 each	1 1/2" Back-up "O" Ring
1 each	1 1/2" Gland "O" Ring
1 each	1" Rod Seal
1 each	1" Wiper

KIT NO. 670086:

Complete assembled 1 1/2" Cylinder Piston with all seals. Consists of:

1 each	1 1/2" Aluminum Middle Piston
1 each	1 1/2" Aluminum Inner Piston
1 each	1 1/2" Aluminum Outer Piston
2 each	1" U-cup Piston Seal
1 each	5/8" Rod "O" Ring

KIT NO. 670087:

All seals needed to service one (1) 1 1/2" Cylinder Gland. Consists of:

1 each	1 1/2" Gland "O" Ring
1 each	1 1/2" Backup Ring
1 each	1" Rod Seal
1 each	1" Rod Wiper

KIT NO. 670088:

All seals needed to service one (1) 1 1/2" Cylinder Piston. Consists of:

2 each	1 Piston Seal
1 each	5/8" Rod "O" Ring

HYDRAULIC CYLINDER PARTS LIST

1 1/2" CYLINDER PARTS LIST:

LIFT CYLINDER (Part No. 670003):

1.....	670060.....	Tube Weldment.....	1
2.....	669994.....	5/8" Locknut	1
3.....	670071.....	Inner Piston Assembly	1
4.....	670072.....	Middle Piston.....	1
5.....	670073.....	Outer Piston Assembly	1
6.....	655023.....	5/8" "O" Ring	1
7.....	670070.....	Gland Assembly.....	1
8.....	670061.....	Rod Weldment	1
	670084.....	Seal Kit	1

BUCKET CYLINDER (Part No. 674004):

1.....	670067.....	Tube Weldment.....	1
2.....	669994.....	5/8" Locknut	1
3.....	670071.....	Inner Piston Assembly	1
4.....	670072.....	Middle Piston	1
5.....	670073.....	Outer Piston Assembly	1
6.....	655023.....	5/8" "O" Ring	1
7.....	670070.....	Gland Assembly.....	1
8.....	670068.....	Rod Weldment	1
	670084.....	Seal Kit	1

HYDRAULIC CYLINDER PARTS DIAGRAM

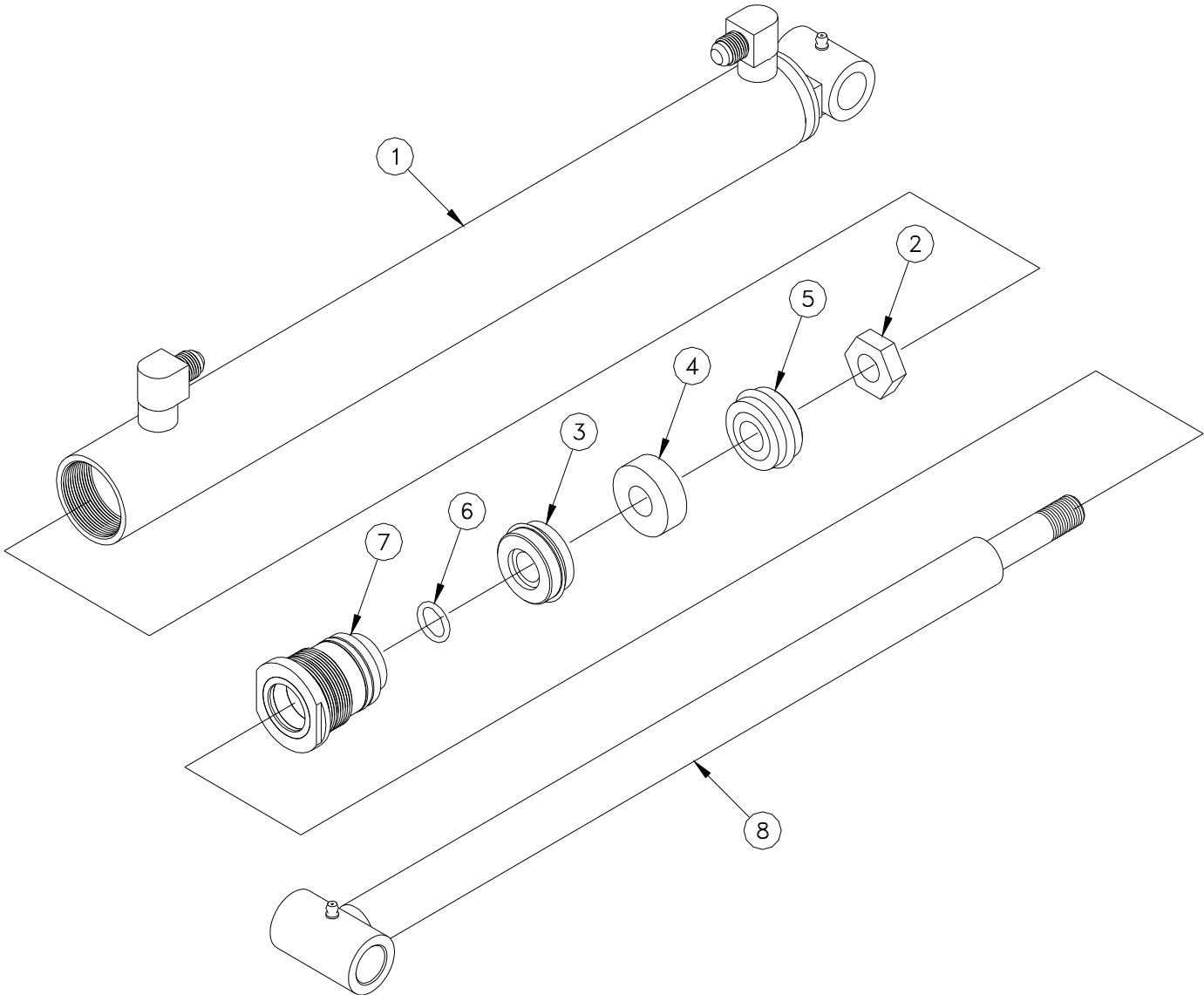

CYLINDER GLAND SERVICE DIAGRAM

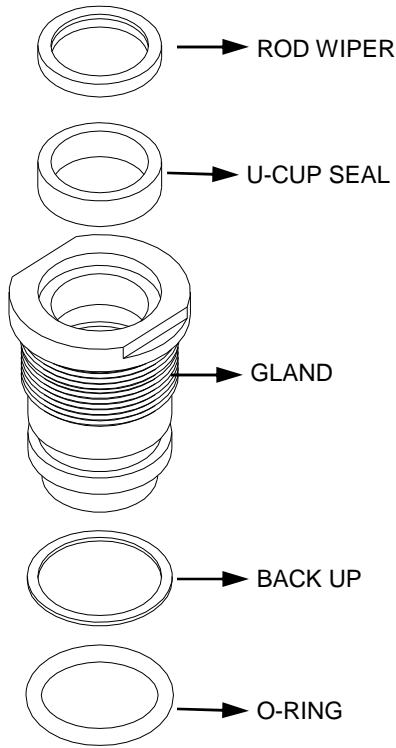

All gland seals shown with a section removed to facilitate correct installation.

Note: To install rod wiper and U-cup seal, fold similar to shape shown below, slip into gland bore and locate each in its respective groove. Tools are used to fold seals, take care not to damage sealing surfaces.

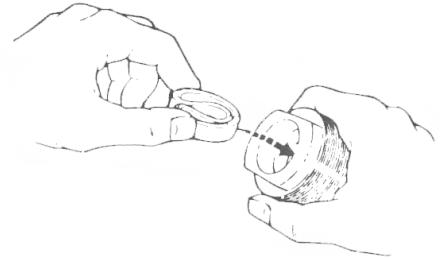
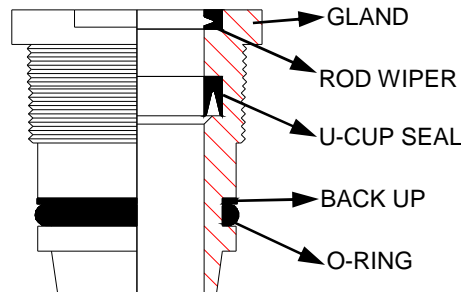

Important! Be sure all gland and piston seals have been installed correctly before cylinder is assembled!

CYLINDER PISTON SERVICE DIAGRAM

To Remove Seals:

Carefully cut across each seal with a sharp knife. Be sure not to scratch sealing surfaces of aluminum piston. If a sharp knife is not available. An electric soldering gun or hot iron may be used to melt throughout seals.

To Install Seals:

1. Thoroughly clean piston sealing surface of all foreign matter.
2. Heat new seals in hydraulic oil to 160° F. Never use a direct flame or heated water on hydraulic seals.
3. Remove seals from oil, wipe dry and install in piston grooves as shown in illustration at left. Be sure seals have completely seated in piston grooves before allowed to cool.
4. Replace piston on cylinder shaft and assemble cylinder when seals have cooled to room temperature.

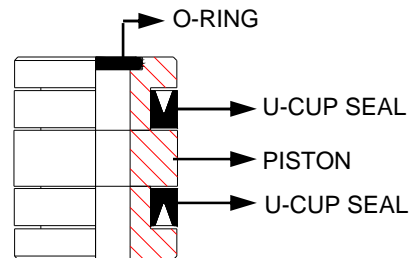
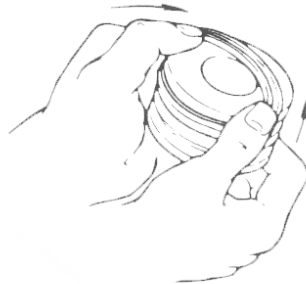
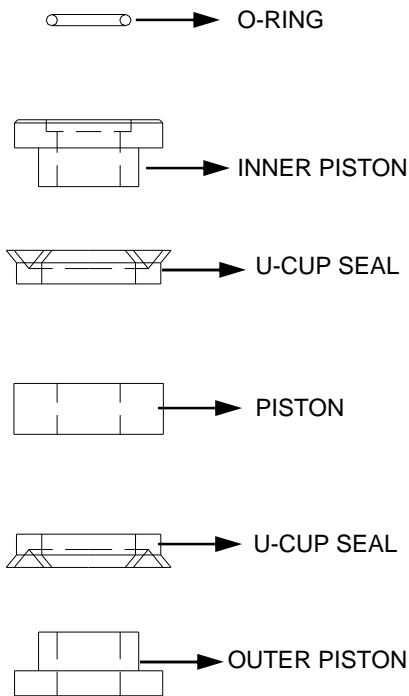

DINOIL VALVE HOOKUP

For power beyond applications item one (655445) plug, must be removed and item two (655444) power beyond sleeve must be added.

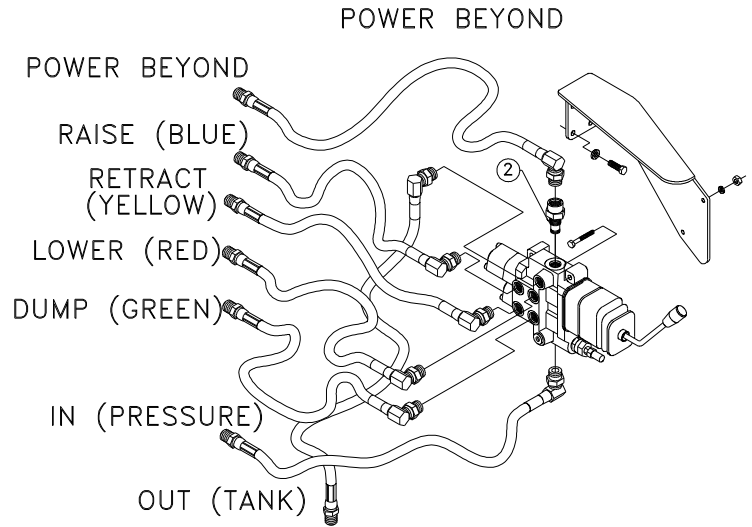

NOTE: Valve normally shipped open center. Part No. #655446 W/Joystick

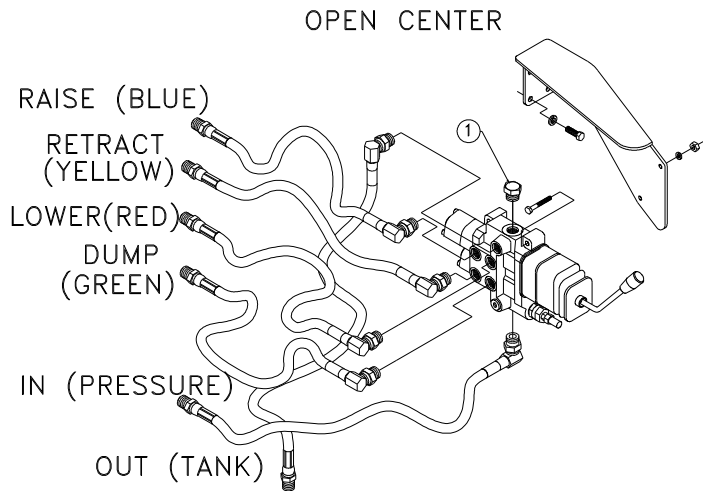

For closed center applications item one (655445) is replaced by item two (655444) and item one is installed in item two.

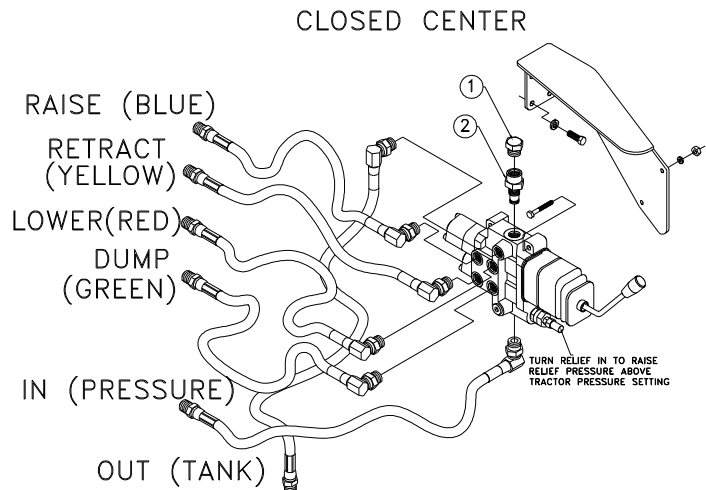



NEW KOYKER FRONT-END LOADER WARRANTY

LIMITED WARRANTY FOR NEW KOYKER MANUFACTURING COMPANY PRODUCTS		
<p>A. GENERAL PROVISIONS. "Koyker" means Koyker Manufacturing Company, 200 N. Cleveland, P.O. Box 409, Lennox, South Dakota 57039. The warranties described below are provided by Koyker to the original purchasers of new products purchased from Koyker or from an authorized Koyker Dealer (the "Products"). Under these warranties, Koyker will, at its option, repair or replace at its factory any Product covered under these warranties which is found to be defective in material and workmanship during the applicable warranty term or refund the purchase price paid for the defective Product. Customer will be responsible for labor charges for removing the defective Product and re-installing the repaired or replacement Product, any premium charge for overtime labor requested of Koyker and shipping charges to and from Koyker's factory. These warranties are not transferrable.</p>		
<p>B. WARRANTY PERIOD. Subject to exclusions and limitations set forth herein, each new Product is warranted for the number of years specified below. Each warranty term begins from the date of purchase regardless of delay in receipt of the Product by Customer due to the time required to process, handle, ship, assemble, construct and install the Product. Customer must retain proof of the date of purchase. Replacement parts for and repairs to the Product will be warranted only for the remainder of the original warranty term. The replacement parts for or repairs to the Product will not extend the warranty term beyond the original warranty term. Products include all parts, components and accessories.</p>		
PRODUCTS		
Koyker Front-End Loaders	Consumer Use	2 years
	Commercial or Government Use	1 year
<p>C. ITEMS COVERED SEPARATELY. The Koyker warranties do not cover any parts, components or materials that are part of the Product, or used in conjunction with the Product, that are not manufactured by Koyker. Such parts, components and materials will be subject to the warranties provided by the manufacturer, if any.</p>		
<p>D. WHAT IS NOT WARRANTED. Koyker does not warrant and is not responsible for the following: (1) used Products; (2) modification or alteration of the Products; (3) Products that have not been properly installed or not installed in accordance with the instruction manual, improper assembly, or improper construction by any persons other than Koyker employees; (4) depreciation, damage or loss caused by the use of parts, components or accessories not provided by Koyker, unauthorized repairs, normal wear, lack of necessary and proper maintenance, a failure to follow operating instructions/recommendations, misuse, lack of proper protection during storage, vandalism or theft, exposure to the elements or corrosive materials, accidents or acts of nature including lightning, flooding, hail, straight winds and tornadoes; and (5) cosmetic damage or damage that does not hinder the functionality of the Products.</p>		
<p>E. LIMITATIONS OF WARRANTIES AND CUSTOMER'S REMEDIES. To the extent permitted by law, neither Koyker, the Dealer nor any person or company affiliated with either of them makes any warranties, representations, conditions or promises express or implied as to the quality, performance or freedom from defects of the Products covered by these warranties other than those set forth herein. THERE ARE NO IMPLIED WARRANTIES OF MERCHANTABILITY OR FITNESS FOR A PARTICULAR PURPOSE. NEITHER KOYKER, THE DEALER, NOR ANY PERSON OR COMPANY AFFILIATED WITH EITHER OF THEM WILL BE LIABLE FOR ANY DAMAGES, INCLUDING, BUT NOT LIMITED TO, INCIDENTAL, SPECIAL, EXEMPLARY, CONSEQUENTIAL, LOST PROFITS AND REVENUES, LOST USE OF THE PRODUCTS OR ANY OTHER PROPERTY, BODILY INJURY OR PROPERTY DAMAGE CLAIMS OF ANY PERSON, LOST COMMODITIES, REMOVAL OR STORAGE COSTS FOR THE PRODUCTS, OTHER EQUIPMENT AND COMMODITIES, DAMAGE TO THE ENVIRONMENT ARISING FROM OR IN ANY MANNER RELATED TO ANY RELEASE OF HAZARDOUS MATERIALS, AND REMEDIATION EXPENSES THEREFORE, WHETHER BASED ON CONTRACT, TORT, STRICT LIABILITY OR ANY OTHER LEGAL BASIS, EVEN IF ADVISED OF THE POSSIBILITY OF SUCH DAMAGES. IN NO INSTANCE WILL KOYKER, THE DEALER OR ANY PERSON OR COMPANY AFFILIATED WITH EITHER OF THEM BE LIABLE TO CUSTOMER OR ANY PERSON IN AN AMOUNT IN EXCESS OF THE PURCHASE PRICE PAID BY CUSTOMER FOR THE PRODUCT.</p>		
<p>F. NO DEALER WARRANTY. THE DEALER HAS NO AUTHORITY TO MAKE ANY WARRANTY, REPRESENTATION, CONDITION OR PROMISE ON BEHALF OF KOYKER, OR TO MODIFY THE TERMS OR LIMITATIONS OF THIS WARRANTY IN ANY WAY.</p>		
<p>G. GOVERNING LAW/VENUE. These warranties, and all terms set forth herein, are governed by the laws of the State of South Dakota and, where applicable, the laws of the United States of America. Any and all disputes arising from these warranties, the purchase and use of the Products, bodily injury and property damage claims or otherwise must be venued in the South Dakota Circuit Court sitting in Minnehaha County, South Dakota. Customer agrees to such venue and waives any challenge to such court's jurisdiction based upon lack of personal jurisdiction or inconvenience.</p>		
<p>H. SECURING WARRANTY SERVICE. In order to receive warranty services, customer must give Koyker written notice of a warranty claim within 30 days of the date of discovery of the defective materials or workmanship, and Customer must complete the following steps:</p>		
(1)	Obtain from Koyker a Return Materials Authorization Number ("RMA Number") by calling the Customer Service Department at 1-800-456-1107 or e-mail Koyker at koyker@koykermfg.com , and providing the following information:	
	An explanation as to why the Product is being returned.	
	The name of the territory representative, Dealer or Koyker salesperson from whom the Product was purchased.	
	The Dealer's identification number.	
	The invoice number and date of purchase.	
	Customer's name, phone number, fax number, mailing address and email address.	
	The date that the Product will be returned.	
(2)	Pay the shipping charges to ship the Product to Koyker's factory, and the return shipping charges.	
(3)	Ship the Product to Koyker at 200 N. Cleveland, Lennox, South Dakota 57039.	